

Service Manual

QUARTZ Synthesizer FM/AM Stereo Tuner

ST-S8(K)

[E], [EG], [EF], [EH],
[EB], [EK], [XA], [XL]

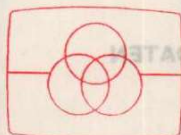

Free service manuals
Gratis schema's

Digitized by

www.freeservicemanuals.info

Areas

- * [E] is available in Switzerland and Scandinavia.
- * [EG] is available in F.R. Germany.
- * [EF] is available in France.
- * [EH] is available in Holland.
- * [EB] is available in Belgium.
- * [EK] is available in United Kingdom.
- * [XA] is available in Southeast Asia, Oceania, Africa, Middle Near East and Central South America.
- * [XL] is available in Australia.

English

Specifications

(Specifications are subject to change without notice for further improvement.)

(DIN 45 500)

FM TUNER SECTION

Frequency range	87.50~108.02 MHz
Sensitivity	0.95 μ V (IHF, usable)
S/N 30 dB	0.95 μ V (75 Ω)
S/N 26 dB	0.85 μ V (75 Ω)
S/N 20 dB	0.75 μ V (75 Ω)
IHF 46 dB stereo quieting sensitivity	20 μ V/75 Ω
Total harmonic distortion	
MONO (normal)	0.04%
STEREO (normal)	0.06%
S/N	
MONO	72 dB (80 dB, IHF)
STEREO	67 dB (74 dB, IHF)
Frequency response	5 Hz~18 kHz, +0.2 dB~-0.5 dB
Alternate channel selectivity	
normal \pm 400 kHz	55 dB
super narrow \pm 200 kHz	25 dB
Capture ratio	1.0 dB
Image rejection at 98 MHz	120 dB
IF rejection at 98 MHz	140 dB
Spurious response rejection at 98 MHz	120 dB
AM suppression	55 dB
Stereo separation	
1 kHz	55 dB
10 kHz	40 dB

Carrier leak

19 kHz	-65 dB (-70 dB, IHF)
38 kHz	-48 dB (-50 dB, IHF)
Channel balance (250 Hz~6,300 Hz)	\pm 1.0 dB
Limiting point	0.75 μ V

Bandwidth

IF amplifier	180 kHz
FM demodulator	1000 kHz
Antenna terminals	75 Ω (unbalanced)

AM TUNER SECTION

Frequency range	522~1611 kHz (9 kHz-step) 530~1620 kHz (10 kHz-step)
Sensitivity (S/N 20 dB)	30 μ V, 250 μ V/m
Selectivity (\pm 9 kHz)	55 dB
Image rejection at 999 kHz	55 dB
IF rejection at 999 kHz	45 dB

GENERAL

Output voltage	0.3V (0.6V, IHF)
Power consumption	11W
Power supply	AC 50 Hz/60 Hz, 110V/120V/220V/240V
Dimensions (W×H×D)	430 × 53 × 390 mm (16-15/16" × 2-3/32" × 15-11/32")
Weight	4.3 kg (9.5 lb.)

Technics

Matsushita Electric Trading Co., Ltd.
P.O. Box 288, Central Osaka Japan

(DIN 45 500)**■ UKW-TUNERTEIL**

Wellenbereich	87,50 ~ 108,02 MHz
Eingangsempfindlichkeit	0,95 μ V (nutzbar nach IHF)
S/R 30 dB	0,95 μ V (75 Ω)
S/R 26 dB	0,85 μ V (75 Ω)
S/R 20 dB	0,75 μ V (75 Ω)
Stereumschaltsschwelle bei 46 dB nach IHF	20 μ V/75 Ω
Gesamtklirrfaktor	
Mono (normal)	0,04%
Stereo (normal)	0,06%
Geräuschabstand	
Mono	72 dB (80 dB nach IHF)
Stereo	67 dB (74 dB nach IHF)
Frequenzgang	5 Hz ~ 18 kHz (+0,2 dB ~ -0,5 dB)
Trennschärfe bei Störsender	
normal \pm 400 kHz	55 dB
super narrow \pm 200 kHz	25 dB
Einfangverhältnis	1,0 dB
Spiegelfrequenz-Dämpfung bei 98 MHz	120 dB
ZF-Dämpfung bei 98 MHz	140 dB
Ansprechdämpfung auf Nebenfrequenzen bei 98 MHz	120 dB
AM-Unterdrückung	55 dB
Übersprechdämpfung	
1 kHz	55 dB
10 kHz	40 dB

Trägerrest

19 kHz	-65 dB (-70 dB nach IHF)
38 kHz	-48 dB (-50 dB nach IHF)
Kanalabweichung (250 Hz ~ 6300 Hz)	\pm 1,0 dB
Begrenzereinsatz	0,75 μ V
Bandbreite	
ZF-Verstärker	180 kHz
UKW-Demodulator	1000 kHz
Antennenanschluß	75 Ω (unsymmetrisch)

■ AM-TUNERTEIL

Wellenbereiche	522 ~ 1611 kHz (9-kHz-Schritte) 530~1620 kHz (10-kHz Schritte)
Eingangsempfindlichkeit (S/R 20 dB)	30 μ V, 250 μ V/m
Trennschärfe (\pm 9 kHz)	55 dB
Spiegelfrequenz-Dämpfung bei 999 kHz	55 dB
ZF-Dämpfung bei 999 kHz	45 dB

■ ALLGEMEINE DATEN

Ausgangsspannung	0,3 V (0,6 V, IHF)
Leistungsaufnahme	11W
Netzspannung	Wechselstrom 50 Hz/60 Hz, 110V/120V/220V/240V
Abmessungen (B×H×T)	430 × 53 × 390 mm
Gewicht	4,3 kg

Français**CARACTERISTIQUES**

(Sujet à changement sans préavis.)

(DIN 45 500)**■ SECTION SYNTONISATEUR FM**

Gamme de fréquence	87,50~108,02 MHz
Sensibilité	0,95 μ V (IHF utilisable)
S/B 30 dB	0,95 μ V (75 Ω)
S/B 26 dB	0,85 μ V (75 Ω)
S/B 20 dB	0,75 μ V (75 Ω)
Sensibilité stéréo au seuil de 46 dB, IHF	20 μ V/75 Ω
Distorsion harmonique totale	
MONO (normal)	0,04%
STEREO (normal)	0,06%
Signal/Bruit	
MONO	72 dB (80 dB, IHF)
STEREO	67 dB (74 dB, IHF)
Réponse de fréquence	5 Hz~18 kHz, +0,2 dB~ -0,5 dB
Sélectivité alternée par canal	
normal \pm 400 kHz	55 dB
super narrow \pm 200 kHz	25 dB
Taux de capture	1,0 dB
Rejection d'image à 98 MHz	120 dB
Rejection FI à 98 MHz	140 dB
Rejection de réponse parasite à 98 MHz	120 dB
Suppression AM	55 dB
Séparation stéréophonique	
1 kHz	55 dB
10 kHz	40 dB

Fuite de porteuse

19 kHz	-65 dB (-70 dB, IHF)
38 kHz	-48 dB (-50 dB, IHF)
Equilibrage de canaux (250 Hz~6,300 Hz)	\pm 1,0 dB
Point de limite	0,75 μ V
Largeur de bande	
Amplificateur FI	180 kHz
Démodulateur FM	1000 kHz
Bornes d'antenne	75 Ω (asymétrique)

■ SECTION SYNTONISATEUR AM

Gamme de fréquence	522~1611 kHz (9 kHz par palier) 530~1620 kHz (10 kHz par palier)
Sensibilité (S/B 20 dB)	30 μ V, 250 μ V/m
Sélectivité (\pm 9 kHz)	55 dB
Réjection d'image à 999 kHz	55 dB
Réjection FI à 999 kHz	45 dB

■ DIVERS

Tension de sortie	0,3 V (0,6V, IHF)
Consommation	11W
Alimentation	CA 50 Hz/60 Hz, 110V/120V/220V/240V
Dimensions (L×H×Pr)	430 × 53 × 390 mm
Poids	4,3 kg

CONTENTS

	Page
LOCATION OF CONTROLS	3
DISASSEMBLY INSTRUCTIONS	4,5
MEASUREMENTS AND ADJUSTMENTS (English)	6~8
EINSTELLUNGSANWEISUNGEN (Deutsch)	8~10
INSTRUCTIONS DE REGLAGE (Français)	11~13
ADJUSTMENT POINTS	14
REPLACEMENT PARTS LIST (Electric Parts)	15, 16, 28, 29
CIRCUIT BOARD AND WIRING CONNECTION DIAGRAM	17 ~ 20
BLOCK DIAGRAM	21, 22
SCHEMATIC DIAGRAM	23 ~ 27
REPLACEMENT PARTS LIST (Cabinet and Chassis Parts)	30
EXPLODED VIEWS	31, 32

LOCATION OF CONTROLS

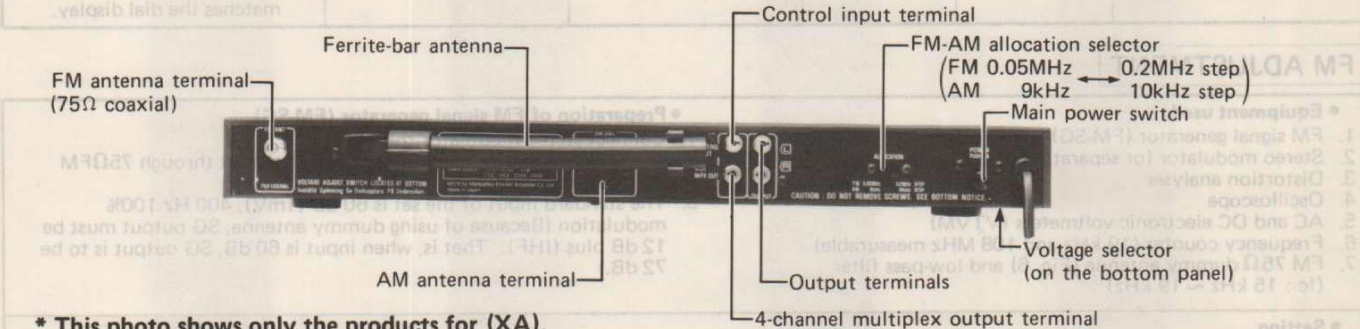
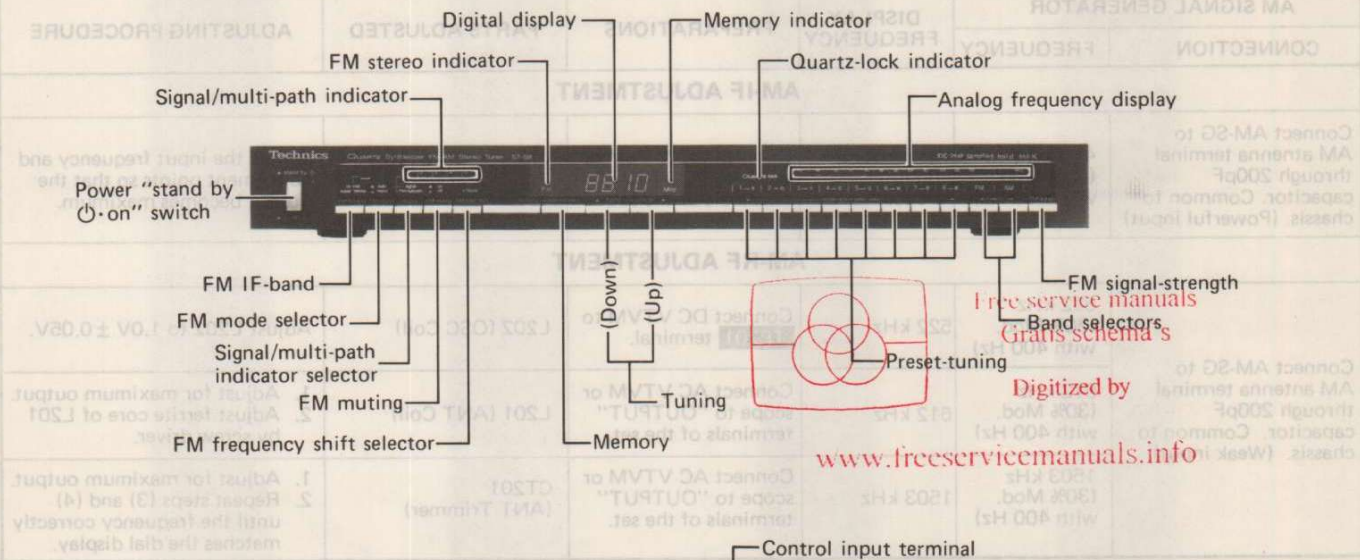

* This photo shows only the products for (XA).
 * The product for other destinations except (XA) is not equipped with FM allocation switch.

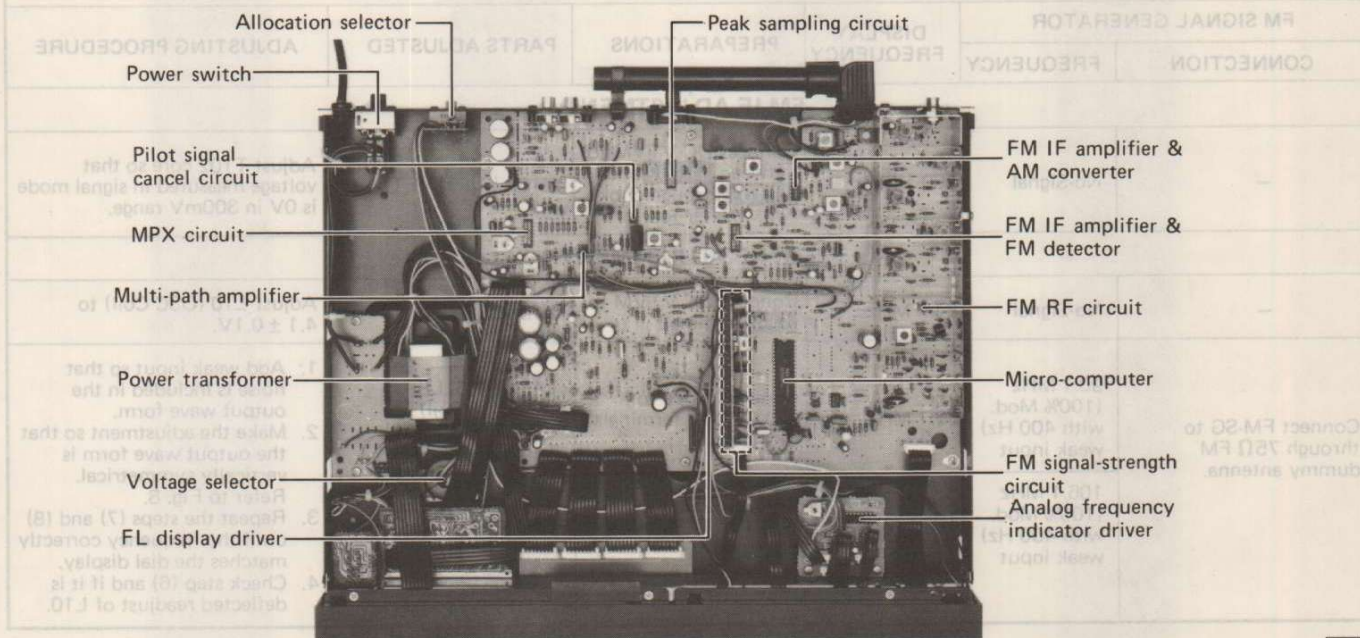

DISASSEMBLY INSTRUCTIONS

How to remove the cabinet

Remove the 4 setscrews (1 ~ 4 in Fig. 1) of the cabinet.

How to remove the front panel

1. Remove the cabinet.
2. Remove the 6 setscrews (5 ~ 10 in Fig. 1) of front panel and the setscrew (11 in Fig. 1) of reinforcement.
3. Remove the front panel from the chassis as in Fig. 2.

How to remove the printed circuit board

C Printed circuit boards (FM/AM IF-RF circuit; FM MPX circuit; FL display circuit; Power supply circuit).

1. Remove the cabinet.
2. Remove the 5 setscrews (13 ~ 17 in Fig. 1) of the printed circuit board, 2 setscrews (18, 19 in Fig. 1) of the output terminal plate, and 2 setscrews (20, 21 in Fig. 1) of the shielding plate.
3. Remove the 2 setscrews (22, 23 in Fig. 1) of the allocation switch.
4. Cut off the lead clumper (12 in Fig. 1).
5. Disconnect the 4 leads of the AM bar antenna.
6. When checking the printed circuit board, raise the printed circuit board as shown in Fig. 3.

Note:

1. When checking the state of receiving AM broadcast, connect the 4 leads to the terminals by the use of clip-attached leads, etc.
2. When connecting the leads after checking the printed circuit board, wind each lead around the terminal and solder as shown in Fig. 3 (A).

F Printed circuit board (Preset tuning switch and Analog frequency indicator circuit).

1. Remove the cabinet and front panel.
2. Turn over the front panel as shown in Fig. 4.
3. Remove the 2 setscrews (24, 25 in Fig. 4) of the printed circuit board. Remove the board in the direction of the arrow (A).

E Printed circuit board (Memory and tuning switch circuit).
 Remove the printed circuit board by pressing the lugs (3 portions) with a screwdriver. (Fig. 4)

H Printed circuit board (Signal/multi-path indicator circuit).
 Remove the printed circuit board by shifting the lugs (2 portions) in the direction of the arrow (B). (Fig. 4)

J, K Printed circuit board (Scale plate illuminating lamp circuit).

Remove the printed circuit board in the same way as for H Printed circuit board. (Fig. 4)

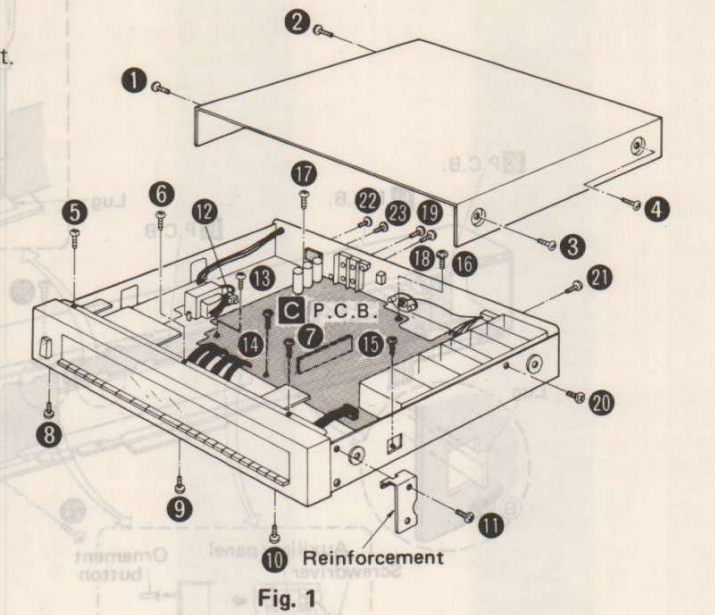

Fig. 1

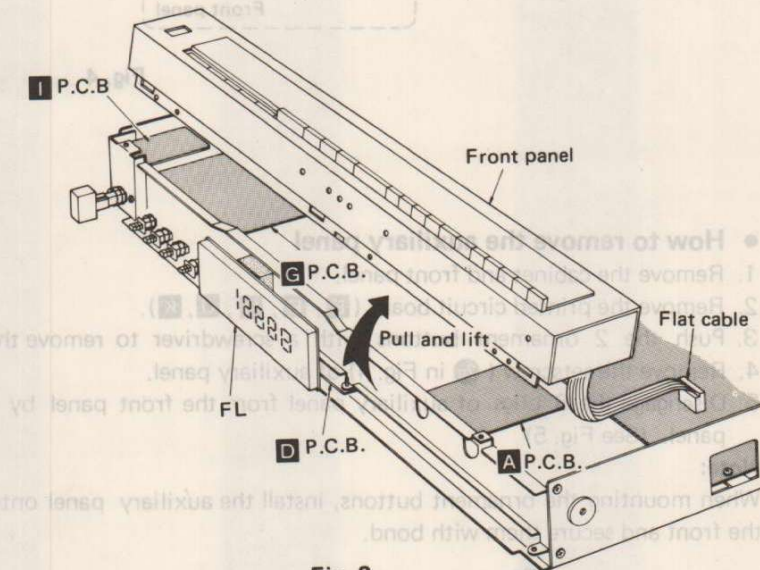

Fig. 2

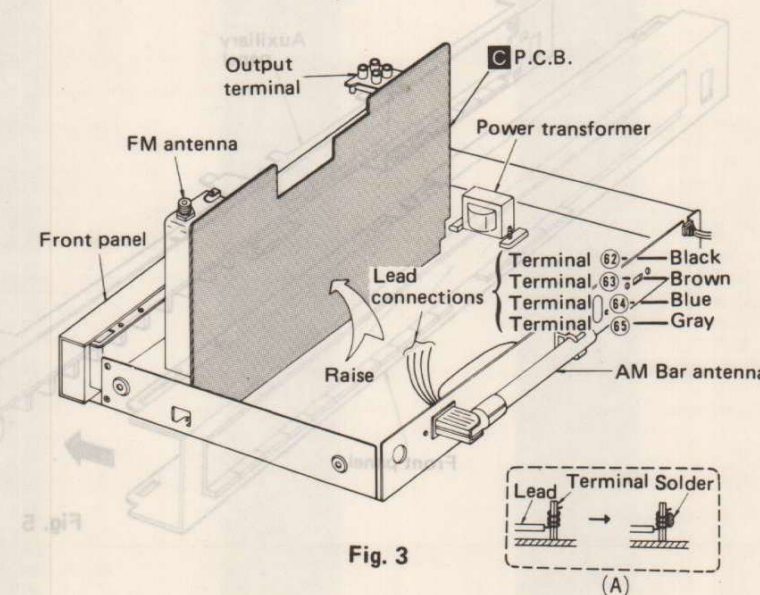

Fig. 3

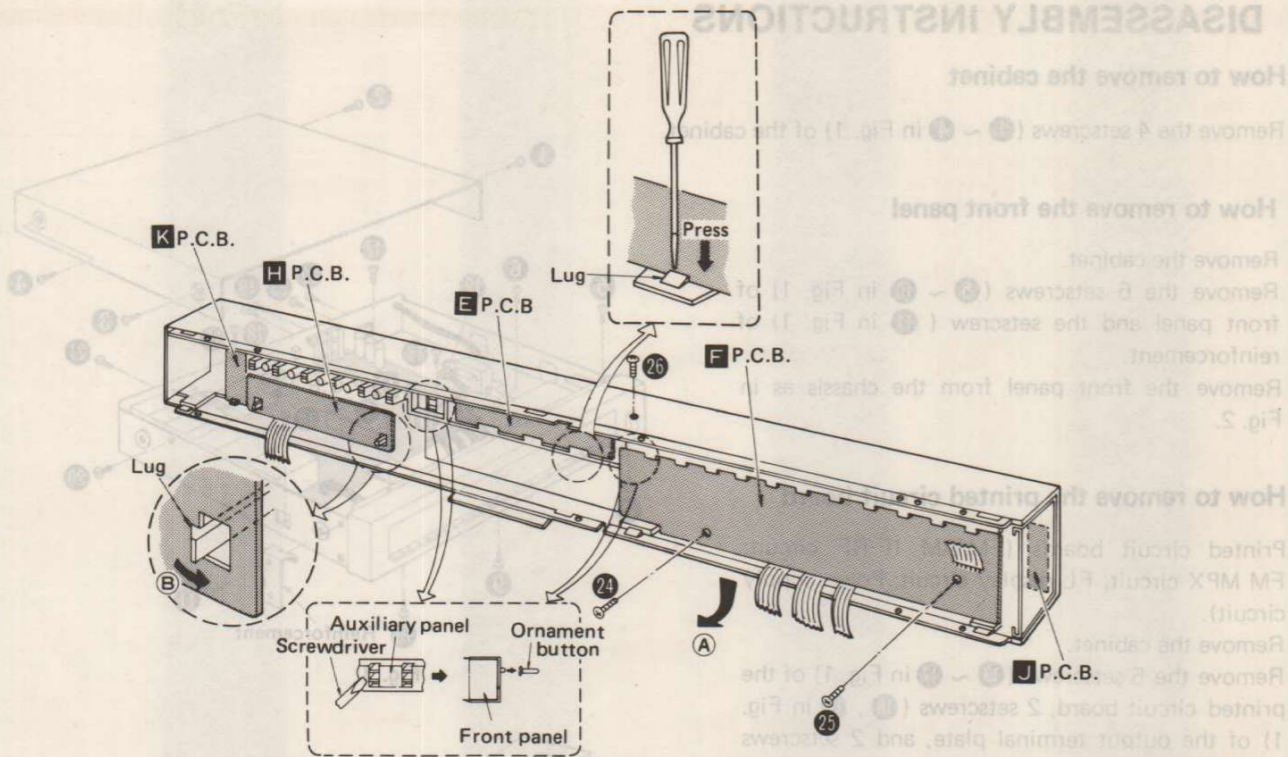

Fig. 4

● How to remove the auxiliary panel

1. Remove the cabinet and front panel.
2. Remove the printed circuit board (E, F, H, J, K).
3. Push the 2 ornament buttons with a screwdriver to remove them from the auxiliary panel (See Fig. 4).
4. Remove the setscrew (26 in Fig. 4) of auxiliary panel.
5. Disengage the 6 Lugs of auxiliary panel from the front panel by using a screwdriver to remove the auxiliary panel. (See Fig. 5)

Note:

When mounting the ornament buttons, install the auxiliary panel onto the front panel, then insert the buttons from the front and secure them with bond.

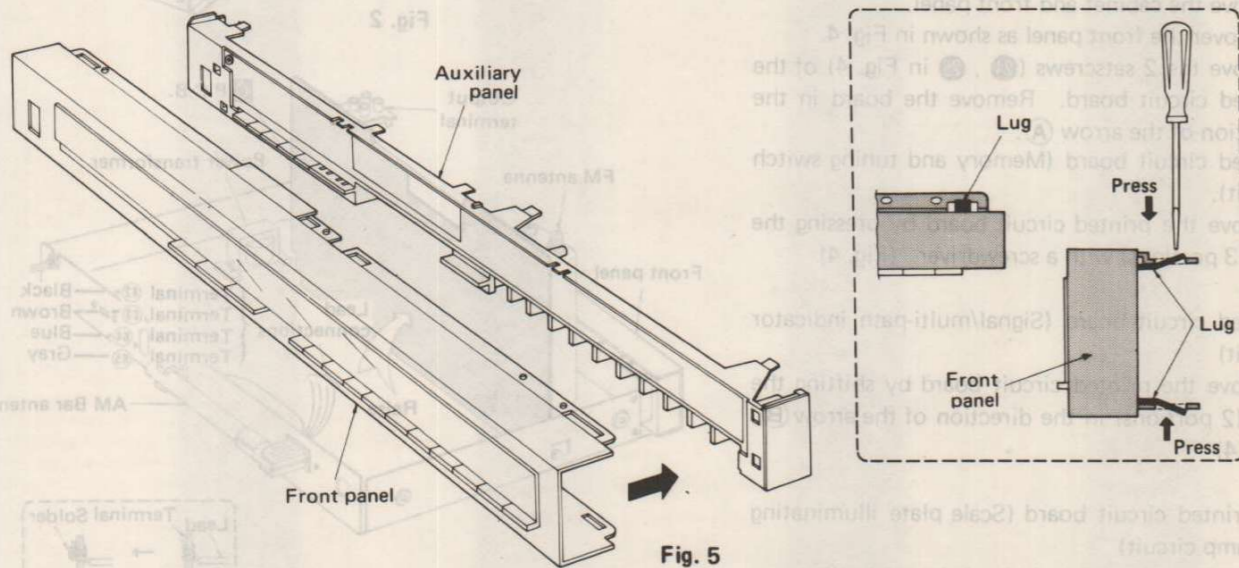

Fig. 5

MEASUREMENTS AND ADJUSTMENTS English

AM ADJUSTMENT

● Setting and Equipment used

1. AC and DC electronic voltmeters (VTVM)
2. AM signal generator (AM-SG)
3. Set band selector to "AM" position.
4. Set AM allocation selector to "9kHz" position.
5. Maintain line voltage at rated voltage.
6. Output of signal generator should be no higher than necessary to obtain an output reading.
7. Adjust the antenna coil (L201) position by using a screwdriver so that it is at approximately 25 degrees to the rear panel.
8. Use a non-metal screwdriver for the adjustment.

Step No.	AM SIGNAL GENERATOR		DISPLAY FREQUENCY	PREPARATIONS	PARTS ADJUSTED	ADJUSTING PROCEDURE
	CONNECTION	FREQUENCY				
AM-IF ADJUSTMENT						
1	Connect AM-SG to AM antenna terminal through 200pF capacitor. Common to chassis. (Powerful input)	450 kHz (30% Mod. with 400 Hz)	Frequency of non-interference	Connect AC VTVM or scope to "OUTPUT" terminals of the set.	L203 (1st IFT) L204 (2nd IFT)	Adjust the input frequency and adjustment points so that the output becomes maximum.
AM-RF ADJUSTMENT						
2		522 kHz (30% Mod. with 400 Hz)	522 kHz	Connect DC VTVM to TP201 terminal.	L202 (OSC Coil)	Adjust L202 to 1.0V ± 0.05V.
3	Connect AM-SG to AM antenna terminal through 200pF capacitor. Common to chassis. (Weak input)	612 kHz (30% Mod. with 400 Hz)	612 kHz	Connect AC VTVM or scope to "OUTPUT" terminals of the set.	L201 (ANT Coil)	1. Adjust for maximum output. 2. Adjust ferrite core of L201 by screw driver.
4		1503 kHz (30% Mod. with 400 Hz)	1503 kHz	Connect AC VTVM or scope to "OUTPUT" terminals of the set.	CT201 (ANT Trimmer)	1. Adjust for maximum output. 2. Repeat steps (3) and (4) until the frequency correctly matches the dial display.

FM ADJUSTMENT

● Equipment used

1. FM signal generator (FM-SG)
2. Stereo modulator (or separation meter)
3. Distortion analyser
4. Oscilloscope
5. AC and DC electronic voltmeters (VTVM)
6. Frequency counter (19 kHz and 108 MHz measurable)
7. FM 75Ω dummy antenna (Fig. 6) and low-pass filter (fc : 15 kHz ~ 19 kHz)

● Preparation of FM signal generator (FM-SG)

1. Connect stereo modulator to FM-SG.
2. Apply SG output to antenna terminal of the set through 75Ω FM dummy antenna.
3. The standard input of the set is 60 dB (1mV), 400 Hz 100% modulation (Because of using dummy antenna, SG output must be 12 dB plus (IHF). That is, when input is 60 dB, SG output is to be 72 dB.)

● Setting

1. Set FM IF band switch to "normal" position.
2. Set FM mode switch to "auto" position.
3. Set Signal/multi-path indicator selector to "signal" position.
4. Set FM muting switch to "off" position.
5. Set band selector to "FM" position.
6. Other setting are the same as in AM adjustment.

Step No.	FM SIGNAL GENERATOR		DISPLAY FREQUENCY	PREPARATIONS	PARTS ADJUSTED	ADJUSTING PROCEDURE
	CONNECTION	FREQUENCY				
FM-IF ADJUSTMENT						
5	-	No-Signal	100.1 MHz	Connect DC VTVM to between TP102 and TP103 through choke coil. (Refer to Fig. 7)	T102 (Discr. IFT)	Adjust T102 core so that voltage measured in signal mode is 0V in 300mV range.
FM-RF ADJUSTMENT						
6	-	No-Signal	87.9 MHz	Connect DC VTVM to TP1 terminal.	L10 (OSC Coil)	Adjust L10 (OSC Coil) to 4.1 ± 0.1V.
7	Connect FM-SG to through 75Ω FM dummy antenna.	90.1 MHz (100% Mod. with 400 Hz) weak input	90.1 MHz	Connect scope to "OUTPUT" terminals of the set.	L4, L5, L6, L8 (RF DET Coil) L1, L2 (ANT Coil) T101 (FM IFT)	1. Add weak input so that noise is included in the output wave form. 2. Make the adjustment so that the output wave form is vertically symmetrical. Refer to Fig. 8.
8		106.1 MHz (100% Mod. with 400 Hz) weak input	106.1 MHz	Connect scope to "OUTPUT" terminals of the set.	CT7 (OSC Trimmer)	3. Repeat the steps (7) and (8) until the frequency correctly matches the dial display. 4. Check step (6) and if it is deflected readjust of L10.

Step No.	FM SIGNAL GENERATOR		DISPLAY FREQUENCY	PREPARATIONS	PARTS ADJUSTED	ADJUSTING PROCEDURE
	CONNECTION	FREQUENCY				
FM MONO DISTORTION ADJUSTMENT						
9	Connect FM-SG to FM antenna terminal through 75Ω FM dummy antenna.	100.1 MHz (100% Mod. with 400 Hz)	100.1 MHz	Connect distortion analyser to "OUTPUT" terminals of the set.	T103 (Discr. IFT)	1. Check step (5) and if it is deflected, readjust of T102. 2. Adjust T103 core so that distortion of right and left channels are minimized.
FM MPX PILOT (VCO) ADJUSTMENT						
10	Connect FM-SG to FM antenna terminal through 75Ω FM dummy antenna.	100.1 MHz (Non-modulated)	100.1 MHz	Connect frequency counter to TP302 terminal.	VR301 (VCO)	Adjust VR301 to 19 kHz ± 30 Hz.
PILOT BAND-PASS FILTER ADJUSTMENT						
11	Connect FM-SG to FM antenna terminal through 75Ω FM dummy antenna. (Pilot 10% Mod. stereo signal)	100.1 MHz (Non-modulated)	100.1 MHz	Connect AC VTVM to TP301 terminal.	L302 L303 (Band pass Filter)	Adjust L302 and L303 so that output voltage is maximum.
PILOT CANCEL ADJUSTMENT						
12	Connect FM-SG to FM antenna terminal through 75Ω FM dummy antenna. (Pilot 10% Mod. stereo signal)	100.1 MHz (Non-modulated)	100.1 MHz	Connect scope to TP303 terminal.	L303 VR303 (Pilot Cancel)	Adjust L303 and VR303 alternately so that the output voltage of TP303 is minimized and the waveform is as shown in Fig. 9.
PHASE SHIFTER ADJUSTMENT						
13	Connect FM-SG to FM antenna terminal through 75Ω FM dummy antenna.	100.1 MHz (100% Mod. with 400 Hz) (L mode)	100.1 MHz	Connect AC VTVM to left ch. "OUTPUT" terminals of the set.	VR302 (Phase Shift)	Adjust VR302 so that L ch. output is maximum.
STEREO DISTORTION ADJUSTMENT						
14	Connect FM-SG to FM antenna terminal through 75Ω FM dummy antenna. (Pilot 10% Mod. stereo signal)	100.1 MHz (100% Mod. with 400 Hz) (L mode)	100.1 MHz	Connect distortion analyser to "OUTPUT" terminals of the set through low-pass filter. (fc = 15 kHz ~ 19 kHz)	T101 (IFT)	1. Re-adjust the already adjusted T101 within ± 90° from the preset core position so that the distortion of L ch is minimized. 2. Re-check the steps 5, 6, 7, 8 and 9.
SEPARATION ADJUSTMENT						
15	Connect FM-SG to FM antenna terminal through 75Ω FM dummy antenna. (Pilot 10% Mod. stereo signal)	100.1 MHz (100% Mod. with 1 kHz) (L or R mode)	100.1 MHz	Connect AC VTVM to "OUTPUT" terminals of the set through low-pass filter. (fc = 15 kHz ~ 19kHz)	VR401 (Separation)	Adjust VR401 so that R output is minimized when stereo modulator is in L (L ch modulation) mode and that L output is minimized in R mode.
SIGNAL LEVEL ADJUSTMENT						
16	Connect FM-SG to FM antenna terminal through 75Ω FM dummy antenna. (Apply 50 dB to the set.)	100.1 MHz (100% Mod. with 400 Hz)	100.1 MHz	—	VR501 (Signal level)	1. Turn signal level semi-fixed resistor VR501 to minimum. (counter-clockwise direction) 2. Adjust VR501 so that the 5 th LED illuminate.
SIGNAL STRENGTH LEVEL ADJUSTMENT * Start the adjustment after power supply for 1 minute at least.						
17	Connect FM-SG to FM antenna terminal through 75Ω FM dummy antenna.	100.1 MHz (100% Mod. with 400 Hz)	100.1 MHz	—	VR502 (Signal strength level)	1. Apply 80 dB to the set. 2. Push the FM signal key so that F.L indicates the signal strength level. 3. Adjust VR502 so that 78 dB is indicated. 4. Make sure that the signal strength level is 36 ~ 48 dB when the input is 40 dB. * If the level is below 36 dB, cut off R590 and re-adjust and check.

Step No.	FM SIGNAL GENERATOR		DISPLAY FREQUENCY	PREPARATIONS	PARTS ADJUSTED	ADJUSTING PROCEDURE
	CONNECTION	FREQUENCY				
QUARTZ LOCK INDICATOR ADJUSTMENT						
18	Connect FM-SG to FM antenna terminal through 75Ω FM dummy antenna. (Apply 6.0 dB to the set.)	100.1 MHz (100% Mod. with 400 Hz)	100.1 MHz	—	VR101 (Quartz lock indicator)	1. Turn VR101 anticlockwise until the quartz lock indicator goes out. 2. Slowly turn VR101 clockwise to adjust it to a point at which the quartz lock indicator lights up.
ANALOG FREQUENCY INDICATOR ADJUSTMENT						
19	Connect FM-SG to FM antenna terminal through 75Ω FM dummy antenna.	107.1 MHz (100% Mod. with 400 Hz)	107.1 MHz	—	VR503 (Analog frequency indicator)	1. Turn VR503 clockwise until the LED, 15 th from the left, goes out. 2. Slowly turn VR503 clockwise to adjust it to a point at which the 15 th LED lights up and 14 th one goes out.

EINSTELLUNGSANWEISUNGEN Deutsch

AM (MW)-EINSTELLUNG

- Stellungen und zu benutzende Geräte**
- Elektronische Voltmeter für Wechsel- und Gleichstrom (VTVM)
 - AM (MW)-Meßsender (AM-SG)
 - Den Wellenbereichsschalter auf die "AM"-Position stellen.
 - Den MW-Intervallgrößenwähler auf die "9kHz"-Position stellen.
 - Netzspannung auf ihren Sollwert halten.
 - Der Ausgang des Meßsenders darf nicht höher sein als unbedingt notwendig für eine gute Ablesung.
 - Nittels eines Schraubenziehers die Stellung der Antennenspule (L201) so einstellen, daß, sie gegen die Rückenplatte einen Winkel von ca. 25° macht.
 - Einen nichtmetallischen Schraubenzieher für die Einstellungen verwenden.

Nr.	AM (MW)-MESSENDER		ANZEIGE-FREQUENZ DURCH VOR-EINSTELLUNG	VORBEREITUNG	ABGLEICHSPUNKTE	ABGLEICHVERFAHREN
	ANSCHLUSS	FREQUENZ				
AM (MW)-ZF-ABGLEICH						
1	Einen MW-Signal-generator über einen 200pF Kondensator mit dem MW-Antenneneingang verbinden. Die gemeinsame Leitung mit dem Chassis verbinden. (Starker Eingang)	450kHz (400Hz Modulat., 30%)	Kein Empfang	Oszilloskop oder Wechselstrom-Voltmeter an Ausgangsklemme (OUTPUT) Schließen.	L203 (1. IFT) L204 (2. IFT)	Die Eingangsfrequenz und die Einstellungspunkte so adjustieren, daß der Ausgang den maximalen Wert erreicht.
AM (MW)-HF-ABGLEICH						
2	Einen MW-Signal-generator über einen 200pF Kondensator mit dem MW-Antenneneingang verbinden. Die gemeinsame Leitung mit dem Chassis verbinden. (Schwacher Eingang)	522kHz (400Hz Modulat., 30%)	522kHz	Zwischen TP201 und Erdung Gleichstrom-Voltmeter schließen.	L202 (Osc. Spule)	L202 so justieren, daß die mit Voltmeter gemessene Spannung 1.0V ± 0.05V beträgt.
3		612kHz (400Hz Modulat., 30%)	612kHz	Oszilloskop oder Wechselstrom-Voltmeter an Ausgangsklemme (OUTPUT) Schließen.	L201 (Ant. Spule)	1. Auf max. Ausgang abgleichen. 2. Den Ferritkern von L201 mit einem Schraubendreher justieren.
4		1503kHz (400Hz Modulat., 30%)	1503kHz	Oszilloskop oder Wechselstrom-Voltmeter an Ausgangsklemme (OUTPUT) Schließen.	CT201 (Ant. Trimmer)	1. Auf max. Ausgang abgleichen. 2. Die Schritte (3) und (4) wiederholen, bis die Frequenz genau mit der Skalenanzeige übereinstimmt.

FM (UKW)-EINSTELLUNG

- Verwendete Einrichtungen**
 1. UKW-Meßsender (FM-SG)
 2. Stereo-Modulator (oder Trennmesser)
 3. Verzerrungsmesser
 4. Oszilloskop
 5. Elektronische Voltmeter für Wechsel- und Gleichstrom (VTVM)
 6. Signalfrequenzmesser (meßbar für 19kHz und 108 MHz)
 7. UKW 75 Ohm Kunstantenne (Abb. 1) und Tiefpaßfilter (fc = 15 ~ 19 kHz)
- Vorbereitung AM UKW-Messender (FM-SG)**
 1. Stereo-Modulator an FM-SG anschließen.
 2. SG-Ausgang über 75-Ohm UKW Kunstantenne an den Antenneneingang des Gerätes schließen.
 3. Der normale Eingang des Gerätes beträgt 60 dB (1 mV), 400 Hz 100% Modulation. (Wegen Verwendung der Kunstantenne muß der Signalausgang 12 dB plus (IHF) sein: d.h. beim Eingang von 60 dB soll der Signalausgang 72 dB sein.)
 4. Den UKW-Stummabstimmsschalter auf die "off"-position stellen.
 5. Den Wellenbereichsschalter auf die "FM" position stellen.
 6. Die anderen Einstellungen entsprechen den AM (MW)-Einstellungen.
- Zustand des Gerätes**
 1. Den UKWZF-Bandbreitenschalter auf die "normal" position stellen.
 2. Den UKW-Betriebsartenschalter auf die "auto" position stellen.
 3. Den Signal-/Mehrweg-Wahlschalter auf die "signal" position stellen.

Nr.	FM (UKW) MESSENDER		ANZEIGE-FREQUENZ DURCH VOR-EINSTELLUNG	VORBEREITUNG	ABGLEICHSPUNKTE	ABGLEICHVERFAHREN
	ANSCHLUSS	FREQUENZ				

UKW-ZF-ABGLEICH						
5	-	Kein Signal	100.1MHz	Ein Gleichstromröhren-voltmeter zwischen TP102 und TP103 über eine Drosselspule verbinden. (Siehe Abb. 2)	T102 (Diskriminator FT)	Den kern von T102 so justieren, daß die gemessene Spannung im signallosen Modus 0 V im 300mV Bereich beträgt.

UKW-HF-ABGLEICH						
6	-	Kein Signal	87.9MHz	Zwischen TP1 und Erdung Gleichstrom-Voltmeter schließen.	L10 (Osc. Spule)	L10 so justieren, daß die vom Gleichstrom-Voltmeter gemessene Spannung 4,1V ± 0,1V beträgt.

7	Meßsender über eine Kunstantenne an den UKW-Antenneneingang schließen.	90.1MHz (400 Hz Modulat., 100%)	90.1MHz	Oszilloskop an Ausgangsklemme (OUTPUT) Schließen.	L4, L5, L6, L8 (HF Det. Spule) L1, L2 (Ant. Spule) T101 (IFT)	1. Einen schwachen Eingang geben, bei dem Geräusch in der Ausgangswellenform enthalten wird. 2. So einstellen, daß die Ausgangswellenform vertikal symmetrisch wird. (Abb. 3) 3. Die Einstellung von (7) und (8) wiederholen, bis die Frequenz mit der Skala übereinstimmt. 4. Schritt (6) überprüfen und, falls Abweichung vorhanden, L10 erneut justieren.
		106.1MHz (400 Hz Modulat., 100%)	106.1MHz	Oszilloskop an Ausgangsklemme (OUTPUT) Schließen.	CT7 (Osc. Trimmer)	

ABGLEICH AUF MIN. VERZERRUNG IN STELLUNG UKW-MONO						
9	Meßsender über eine Kunstantenne an den UKW-Antenneneingang schließen.	100.1MHz (400 Hz Modulat., 100%)	100.1MHz	Verzerrungsmesser an rechten und linken Kanäle Ausgangsklemme "OUTPUT" des Gerätes schließen.	T103 (Diskriminator FT)	1. Schritt (5) überprüfen und, falls Abweichung vorhanden, T102 erneut justieren. 2. T103 Kern für minimale Verzerrung der rechten und linken Kanäle justieren.

UKW-MPX-PILOTABGLEICH (VCO)						
10	Meßsender über eine Kunstantenne an den UKW-Antenneneingang schließen. (Mono-Signal)	100.1MHz (Un-modulierte Welle)	100.1MHz	Signal frequenzmesser an TP302 schließen.	VR301 (VCO)	VR301 so abgleichen, daß Ausgangsfrequenz von TP302 19kHz ± 30 Hz

KONTROLL - BANDPASSFILTER - ABGLEICH						
11	Meßsender über eine Kunstantenne an den UKW-Antenneneingang schließen. (Stereo-Pilotsignal 10% moduliert.)	100.1MHz (Un-modulierte Welle)	100.1MHz	Wechselstrom-voltmeter an TP301 schließen.	L302 L303 (Pilot BPF)	L302 und L303 so abstimmen, daß die Ausgangsspannung maximal ist.

KONTROLL - AUFLÖSEN - ABGLEICH						
12	Meßsender über eine Kunstantenne an den UKW-Antenneneingang schließen. (Stereo-Pilotsignal 10% moduliert.)	100.1MHz (Un-modulierte Welle)	100.1MHz	Oszilloskop an TP303 schließen.	L303 VR303 (Kontrollauflösen)	L303 und VR303 abwechselnd so einstellen, daß die Ausgangsspannung am TP303 minimalisiert wird und die Wellenform wie in Abb. 4 erscheint.

Nr.	FM (UKW) MESSENDER		ANZEIGE-FREQUENZ DURCH VOR-EINSTELLUNG	VORBEREITUNG	ABGLEICHSPUNKTE	ABGLEICHVERFAHREN
	ANSCHLUSS	FREQUENZ				

PHASENSCHIFTERABGLEICH						
13	Meßsender über eine Kunstantenne an den UKW-Antenneneingang schließen. (Stereo-Pilotsignal 10% moduliert.)	100.1MHz (400 Hz Modulat., 100%) L-Betriebsart	100.1MHz	Wechselstrom-voltmeter an L-Kanal Ausgangsklemme (OUTPUT) schließen.	VR302 (Phasenregelung)	VR302 so abstimmen, daß die Ausgangsleistung des linken Kanals maximal ist.

STEREO-VERZERRUNGSABGLEICH						
14	Meßsender über eine Kunstantenne an den UKW-Antenneneingang schließen. (Stereo-Pilotsignal 10% moduliert.)	100.1MHz (400 Hz Modulat., 100%) L-Betriebsart	100.1MHz	Tiefpaßfilter (fc = 15 ~ 19kHz) über Verzerrungsmesser an Ausgangsklemme (OUTPUT) des Gerätes schließen.	T101 (IFT)	1. Den schon eingestellten T101 erneut, innerhalb von ± 90° von der voreingestellten kernposition einstellen, sodaß die Verzerrung des linken Kanals minimalisiert wird. 2. Die Schritte 5 ~ 8 und 9 noch einmal überprüfen.

TRENNUNG - ABGLEICH						
15	Meßsender über eine Kunstantenne an den UKW-Antenneneingang schließen. (Stereo-Pilotsignal 10% moduliert.)	100.1MHz (400 Hz Modulat., 100%) L- oder R-Betriebsart	100.1MHz	Tiefpaßfilter (fc = 15 ~ 19kHz) über Wechselstrom-voltmeter an Ausgangsklemme (OUTPUT) des Gerätes schließen.	VR401	VR401 auf minimale Anzeige des R-Ausgangs bei Stereo-modulator in L-(L-Kanal-modulation) Modus, und auf minimale Anzeige des L-Ausgangs in R-Modus abgleichen.

SIGNALPEGEL - ABGLEICH						
16	Meßsender über eine Kunstantenne an den UKW-Antenneneingang schließen. (50dB in den Antenneneingang leiten.)	100.1MHz (400 Hz Modulat., 100%)	100.1MHz		VR501	1. Die signalpegel halbfein-einstellen Widerstände VR501 auf Minimalstellung drehen. (Entgegen dem Uhrzeigersinn) 2. Den einstellbaren Widerstände VR501 so einstellen, daß die fünfte Leuchtdiode (LED) auf leuchtet.

UKW-SIGNALPEGEL-ABGLEICH
 * Mit der Justierung frühestens 1 Minute nach Einschalten der Stromzufuhr beginnen.

17	Meßsender über eine Kunstantenne an den UKW-Antenneneingang schließen.	100.1MHz (400 Hz Modulat., 100%)	100.1MHz		VR502	1. 80dB an das Gerät anlegen. 2. Die UKW-Signalpegel-taste drücken, damit das FL-Instrument den Signalstärkepegel anzeigt. 3. VR502 so justieren, daß 78dB angezeigt wird. 4. Überprüfen, daß der Signalstärkepegel 36 ~ 48dB beträgt, wenn die Eingangssleistung 40dB ist. * Falls der Pegel unter 36dB liegt, R590 abtrennen, erneut justieren und kontrollieren.
----	--	----------------------------------	----------	--	-------	---

QUARZ-VERRIEGELUNGSANZEIGER						
18	Meßsender über eine Kunstantenne an den UKW-Antenneneingang schließen. (6dB in den Antenneneingang leiten.)	100.1MHz (400 Hz Modulat., 100%)	100.1MHz		VR101	1. VR101 entgegen dem Uhrzeigersinn drehen, bis der Quarz-Verriegelungsanzeiger erlischt. 2. VR101 langsam entgegen dem Uhrzeigersinn drehen und auf einen Punkt abstimmen, an welchem der Quarz-Verriegelungsanzeiger aufleuchtet.

ANALOGFREQUENZANZEIGE						
19	Meßsender über eine Kunstantenne an den UKW-Antenneneingang schließen.	107.1MHz (400 Hz Modulat., 100%)	107.1MHz		VR503	1. VR503 im Uhrzeigersinn drehen, bis die 15. LED von links erlischt. 2. VR503 langsam im Uhrzeigersinn drehen und auf einen Punkt abstimmen, an welchem die 15. LED aufleuchtet und die 14. LED erlischt.

INSTRUCTIONS DE REGLAGE **Français**

REGLAGE DE AM

- **Réglage et équipement utilisé**
- 1. Voltmètres électronique de courant alternatif et de courant continu (VTVM).
- 2. Générateur du signal AM (AM-SG).
- 3. Sélecteurs de gammes d'ondes sur la position "AM".
- 4. Sélecteur d'intervalle de fréquence AM sur la position "9kHz".
- 5. Conservez la tension du secteur à la tension nominale.
- 6. Le signal du générateur ne doit pas être plus élevé qu'il n'est nécessaire à obtenir une lecture en sortie.
- 7. Régler la position de la bobine (L201) de l'antenne en utilisant un tournevis de telle sorte qu'elle soit environ à 25 degrés de la plaque arrière.
- 8. Utiliser un tournevis non-métallique pour le réglage.

AM GENERATEUR		FREQUENCE D'AFFICHAGE PAR PREREGLAGE	PREPARATIONS	ELEMENTS REGLES	PROCEDURE DE REGLAGE
BRANCHEMENT	FREQUENCE				

REGLAGE DE FI-AM

No. 1	Brancher le AM-SG à la borne de l'antenne AM par un condensateur de 200pF. Commun au châssis. (Entrée sous puissante).	450kHz (modulé à 30% par 400 Hz)	Point sans signal	Brancher le voltmètre à courant alternatif et l'oscilloscope aux borne de sortie (OUTPUT) de l'appareil.	L203 (1 transfo FI) L204 (2 transfo FI)	Régler la fréquence d'entrée et les points de réglage de telle sorte que la sortie devienne maximale.
-------	--	----------------------------------	-------------------	--	--	---

REGLAGE DE RF-AM

No. 2	Brancher le AM-SG à la borne de l'antenne AM par un condensateur de 200pF. Commun au châssis. (Entrée faible)	522kHz (modulé à 30% par 400 Hz)	522kHz	Brancher le voltmètre à courant continue entre TP201 et la prise terre.	L202 (Bobine OSC)	Régler L202 de telle sorte que le voltage mesuré par le voltmètre à courant continu, soit de $1.0 \pm 0.05 V$.
No. 3		612kHz (modulé à 30% par 400 Hz)	612kHz	Brancher le voltmètre à courant alternatif et l'oscilloscope aux borne de sortie (OUTPUT) de l'appareil.	L201 (Bobine Ant.)	1. Régler au maximum de signal de sortie. 2. Régler le noyau ferrite de L201 à l'aide d'un tournevis.
No. 4		1503kHz (modulé à 30% par 400 Hz)	1503kHz	Brancher le voltmètre à courant alternatif et l'oscilloscope aux borne de sortie (OUTPUT) de l'appareil.	CT201 (Trimmer Ant.)	1. Régler au maximum de signal de sortie. 2. Refaire les étapes (3) et (4) jusqu'à ce que le fréquence s'aligne correctement avec l'affichage du cadran.

REGLAGE DE FM

- **Equipment utilisé**
- 1. Générateur du signal FM (FM-SG).
- 2. Commande de réglage stéréophonique (ou vu-mètre de séparation).
- 3. Jauge de distorsion.
- 4. Oscilloscope.
- 5. Voltmètres électronique de courant alternatif et de courant continu (VTVM).
- 6. Compteur de fréquence (19kHz et 108MHz mesurable).
- 7. Antenne fictive FM, 75 ohms (Fig. 6) et filtre passe-bas ($f_c = 15 \sim 19kHz$)
- **Préparation du générateur de signal FM (FM-SG)**
- 1. Brancher la commande de réglage stéréophonique à FM-SG.
- 2. Alimenter la sortie SG à la borne de l'antenne de l'appareil, par l'antenne fictive FM, 75 ohms.
- 3. L'entrée standard de l'appareil est de 60dB (1mV), 400Hz, 100% de modulation (à cause de l'utilisation de l'antenne fictive, la sortie SG doit être de plus 12dB (IHF). Ce qui signifie que quand l'entrée est de 60dB, la sortie SG doit être de 72dB).

- **Conditions de l'appareil**
- 1. Placer le Interrupteur de gamme FM-IF sur la position "normal".
- 2. Placer le sélecteur de mode FM sur la position "auto".
- 3. Placer le sélecteur de l'indicateur de signal/distorsion d'écho sur la position "signal".
- 4. Placer le commutateur de réglage silencieux FM sur la position "off".
- 5. Placer le sélecteurs de gammes d'ondes sur la position "FM".
- 6. Les autres réglages sont les mêmes que les réglages de AM.

FM GENERATEUR		FREQUENCE D'AFFICHAGE PAR PREREGLAGE	PREPARATIONS	ELEMENTS REGLES	PROCEDURE DE REGLAGE
BRANCHEMENT	FREQUENCE				

REGLAGE DE FI-FM

No. 5	—	Sans Signal	100.1MHz	Brancher le voltmètre électronique à C.C. aux bornes TP102 et TP103 (Voir la Fig. 7)	T102 (Transfo FI discri.)	Régler le noyau T102 de telle sorte que le voltage mesuré dans le mode sans signal, soit de 0V dans la gamme des 300 mV.
-------	---	-------------	----------	--	---------------------------	--

FM GENERATEUR		FREQUENCE D'AFFICHAGE PAR PREREGLAGE	PREPARATIONS	ELEMENTS REGLES	PROCEDURE DE REGLAGE
BRANCHEMENT	FREQUENCE				

REGLAGE DE RF-FM

No. 6	—	Sans Signal	87.9MHz	Brancher le voltmètre à courant continu entre TP1 et la prise de terre.	L10 (Bobin Osc.)	Régler L10 de telle sorte que le voltage mesuré par le voltmètre à courant continu soit de 4,1V.
No. 7		90.1MHz (modulé à 100% par 400 Hz)	90.1MHz	Brancher le voltmètre à courant alternatif et l'oscilloscope aux borne de sortie (OUTPUT) de l'appareil.	L4, L5, L6, L8 (Décteur) L1, L2 (Bobin Ant.) T101 (Transfo FI)	1. Appliquer une entrée faible de telle sorte que le parasite soit compris dans la forme de l'onde de sortie. 2. Faire le réglage de telle sorte que la forme de l'onde de sortie soit verticalement symétrique. (Voir fig. 8) 3. Refaire les réglages (7) et (8) jusqu'à ce que la fréquence corresponde correctement avec l'échells du cadran. 4. Vérifier l'étape (6) et si elle est déviée régler à nouveau L10.
No. 8	Brancher sur la prise d'antenne FM à travers une antenne fictive FM	106.1MHz (modulé à 100% par 400 Hz)	106.1MHz	Brancher le voltmètre à courant alternatif et l'oscilloscope aux borne de sortie (OUTPUT) de l'appareil.	CT7 (Trimmer Osc.)	

REGLAGE DE LA DISTORSION FM EN MONO

No. 9	Brancher sur la prise d'antenne FM à travers une antenne fictive FM.	100.10MHz (modulé à 100% par 400 Hz)	100.1MHz	Brancher le compteur de distorsion à la borne de sortie (OUTPUT) du canal gauche et droit de l'appareil.	T103 (Transfo FI discri.)	1. Vérifier l'étape (5) et si elle est déviée régler à nouveau T102. 2. Régler le noyau T103 de telle sorte que la distorsion des canaux droit et gauche soit la plus faible.
-------	--	--------------------------------------	----------	--	---------------------------	--

REGLAGE (VCO) PILOTE MULTIPLEX FM

No. 10	Brancher sur la prise d'antenne FM à travers une antenne fictive FM. (Signal monoscoustique)	100.1MHz (Non modulé)	100.1MHz	Brancher le compteur de fréquence à TP302.	VR301	Régler VR301 de telle sorte que la fréquence de sortie de TP302 soit de 19kHz \pm 30 Hz.
--------	--	-----------------------	----------	--	-------	--

REGLAGE FILTRE PILOTE PASSE - BANDE

No. 11	Brancher sur la prise d'antenne FM à travers une antenne fictive FM. (Signal stéréo pilote à 10% de modulation)	100.1MHz (Non modulé)	100.1MHz	Brancher un voltmètre à courant alternatif à TP301.	L302 L303 (BPF signal pilote)	Régler la L302 et al L303 de telle sorte que la tension de sortie soit maximale.
--------	---	-----------------------	----------	---	----------------------------------	--

ANNULATION DU SIGNAL PILOTE

No. 12	Brancher sur la prise d'antenne FM à travers une antenne fictive FM. (Signal stéréo pilote à 10% de modulation)	100.1MHz (Non modulé)	100.1MHz	Brancher le voltmètre à courant alternatif et l'oscilloscope à TP303.	L303 VR303	Régler les L303 et VR303 alternativement de telle sorte que la tension de sortie du TP303 soit minimale et que la forme d'ondes soit celle montrée sur la Fig. 9.
--------	---	-----------------------	----------	---	---------------	---

REGLAGE DU DEPHASEUR

No. 13	Brancher sur la prise d'antenne FM à travers une antenne fictive FM. (Signal stéréo pilote à 10% de modulation)	100.1MHz (modulé à 100% par 400 Hz) (Mode G)	100.1MHz	Brancher un voltmètre à courant continu à la borne de sortie du canal gauche.	VR302	Régler la VR302 de telle sorte que la sortie du canal gauche, soit maximale.
--------	---	--	----------	---	-------	--

REGLAGE DE LA DISTORSION STEREO

No. 14	Brancher sur la prise d'antenne FM à travers une antenne fictive FM (Signal stéréo pilote à 10% de modulation)	100.1MHz (modulé à 100% par 400 Hz) (Mode G)	100.1MHz	Brancher le filtre passe-bas ($f_c = 15 \sim 19kHz$) à la borne de sortie (OUTPUT) de l'appareil par un distorsion à courant alternatif.	T101	1. Rerégler le T101 déjà réglé, à $\pm 90^\circ$ de la position préréglée du noyau de telle sorte que la distorsion du canal gauche soit minimale. 2. Revérifier les étapes 5 ~ 8 et 9.
--------	--	--	----------	--	------	--

FM GENERATEUR		FREQUENCE D'AFFICHAGE PAR PREREGLAGE	PREPARATIONS	ELEMENTS REGLES	PROCEDURE DE REGLAGE
BRANCHEMENT	FREQUENCE				

REGLAGE DE LA SEPARATION DES CANAUX

No. 15	Brancher sur la prise d'antenne FM à travers une antenne fictive FM. (Signal stéréo pilote à 10% de modulation)	100.1MHz (modulé à 100% par 400 Hz) (Mode G ou D.)	100.1MHz	Brancher le filter passe-bas ($f_c = 15 \sim 19kHz$) à la borne de sortie (OUTPUT) de l'appareil par un voltmètre à courant alternatif.	VR401	Régler VR401 de telle sorte que la sortie droite soit minimale quand la commande d'accord stéréophonique est dans le mode gauche (modulation du canal gauche) et que la sortie gauche soit minimale dans mode droit.
--------	---	--	----------	---	-------	--

INDICATEUR DE SIGNAL

No. 16	Brancher sur la prise d'antenne FM à travers une antenne fictive FM. (Appliquer 50dB à la borne de l'antenne.)	100.1MHz (modulé à 100% par 400 Hz)	100.1MHz		VR501	1. Tourner les résistances VR501 semifixes sur le minimum. (à gauche.) 2. Régler la VR501 de telle sorte que la 5ème LED s'allume.
--------	--	-------------------------------------	----------	--	-------	---

INDICATEUR D'INTENSITE DES SIGNAUX FM

* Commencer la mise au point apres 1 minute au moins la mise en marche de l'alimentation.

No. 17	Brancher sur la prise d'antenne FM à travers une antenne fictive FM.	100.1MHz (modulé à 100% par 400 Hz)	100.1MHz		VR502	1. Appliquer 80dB à l'appareil. 2. Appuyer sur la touche de signaux FM de façon à ce que le F.L. indique le niveau d'intensité des signaux. 3. Régler VR502 de façon à ce que 78 dB soit indiqué. 4. S'assurer que le niveau d'intensité des signaux soit de 36 ~ 48dB lorsque l'entrée est de 40dB. * Si le niveau est au-dessous de 36dB, mettre hors circuit R590, régler à nouveau et vérifier.
--------	--	-------------------------------------	----------	--	-------	---

INDICATEUR DE VERROUILLAGE QUARTZ

No. 18	Brancher sur la prise d'antenne FM à travers une antenne fictive FM. (Appliquer 6dB à la borne de l'antenne.)	100.1MHz (modulé à 100% par 400 Hz)	100.1MHz		VR101	1. Tourner VR101 dans le sens inverse des aiguilles d'une montre jusqu'à ce que l'indicateur de verrouillage à quartz s'éteigne. 2. Tourner lentement VR101 dans le sens des aiguilles d'une montre pour le régler au point auquel l'indicateur de verrouillage à quartz s'allumera.
--------	---	-------------------------------------	----------	--	-------	---

INDICATEUR DE ANALOGIQUE

No. 19	Brancher sur la prise d'antenne FM à travers une antenne fictive FM.	107.1MHz (modulé à 100% par 400 Hz)	107.1MHz		VR503	1. Tourner VR503 dans le sens des aiguilles d'une montre jusqu'à ce que la diode électro-luminescente, la 15e à partir de la gauche, s'éteigne. 2. Tourner lentement VR503 dans le sens des aiguilles d'une montre pour le régler au point auquel la 15e diode électro-luminescente s'éclairera et la 14e s'éteindra.
--------	--	-------------------------------------	----------	--	-------	--

ADJUSTMENT POINTS

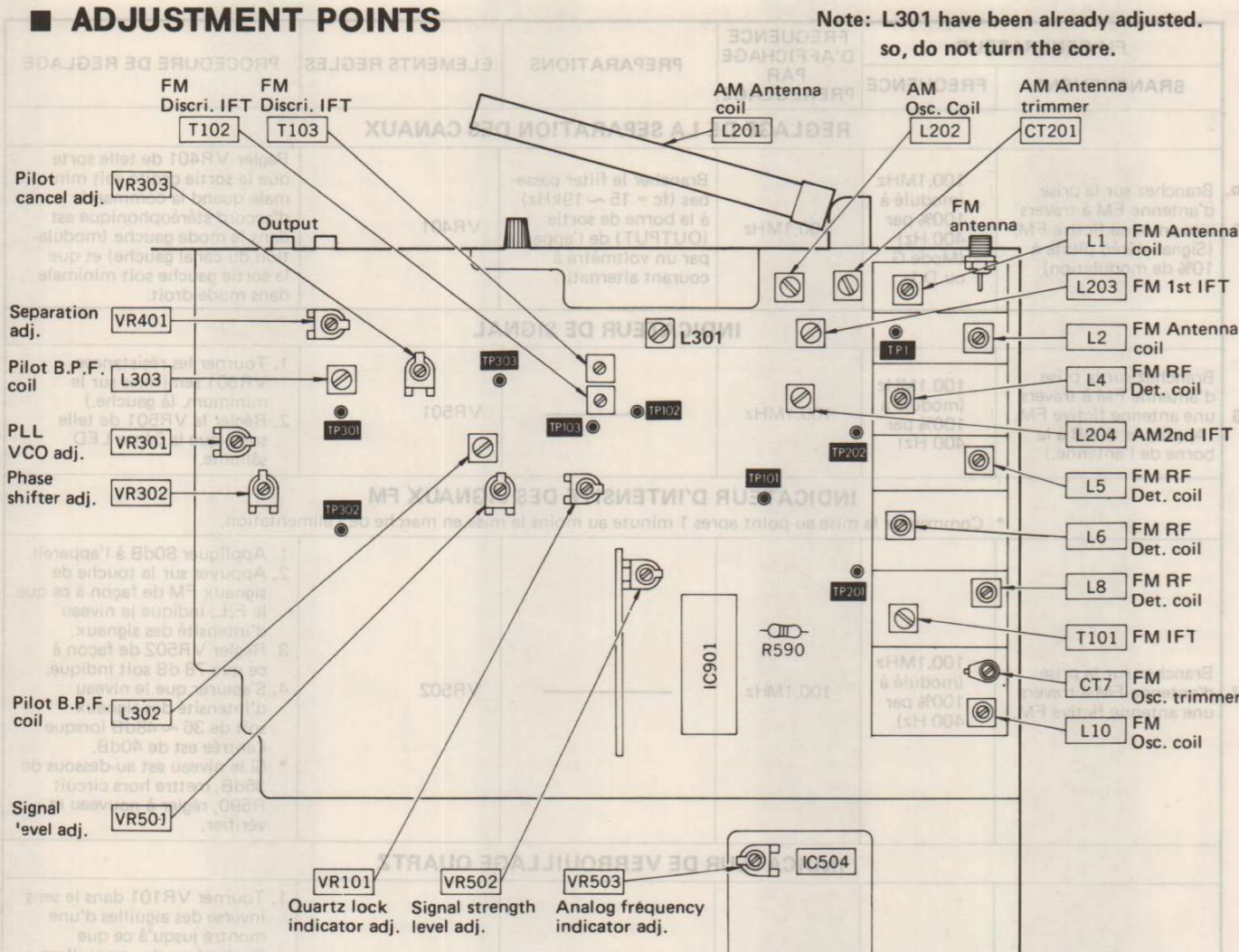

Note: L301 have been already adjusted, so, do not turn the core.

REPLACEMENT PARTS LIST ... Electric Parts

Notes: 1. Part numbers are indicated on most mechanical parts. Please use this part number for parts orders. 2. Important safety notice: Components identified by Δ mark have special characteristics important for safety. When replacing any of these components, use only manufacturer's specified parts. 3. Bracketed indications in Ref. No. columns specify the area. Parts without these indications can be used for all areas.

- Areas
* [E] is available in Switzerland and Scandinavia.
* [EG] is available in F.R. Germany.
* [EF] is available in France.
* [EH] is available in Holland.
* [EB] is available in Belgium.
* [EK] is available in United Kingdom.
* [XA] is available in Southeast Asia, Oceania, Africa, Middle Near East and Central South America.
* [XL] is available in Australia.

Table with 3 columns: Ref. No., Part No., Part Name & Description. Section: INTEGRATED CIRCUITS. Includes parts like SVIM5215L, SVIUCP1018CF, SVIUCP1167C2, etc.

Table with 3 columns: Ref. No., Part No., Part Name & Description. Section: TRANSISTORS. Includes parts like 3SK74-L1, 2SC1674-M, 2SC1675-L, etc.

Table with 3 columns: Ref. No., Part No., Part Name & Description. Section: DIODES. Includes parts like SVDSVC211, MA162A, 20A90, etc.

Table with 3 columns: Ref. No., Part No., Part Name & Description. Section: DIODES. Includes parts like SVDGL-9PR9, SVDGL-9HY9, SVDMZ303BM, etc.

Table with 3 columns: Ref. No., Part No., Part Name & Description. Section: COILS and TRANSFORMERS. Includes parts like SLA4P65, SLD4P43, SLQAN40G1, etc.

Table with 3 columns: Ref. No., Part No., Part Name & Description. Section: TRANSFORMERS. Includes parts like SLI4C109, SLI4C529-Z, SLI4C531-Z, etc.

Table with 3 columns: Ref. No., Part No., Part Name & Description. Section: CERAMIC FILTERS. Includes parts like SVFE107MX2-A, SVFE107MX2-D, etc.

Table with 3 columns: Ref. No., Part No., Part Name & Description. Section: VARIABLE RESISTORS. Includes parts like EVTS3MA00B34, EVTS3MA00B53, etc.

Table with 3 columns: Ref. No., Part No., Part Name & Description. Section: CRYSTAL. Includes part SVQ43U452.

Table with 3 columns: Ref. No., Part No., Part Name & Description. Section: VARIABLE CAPACITORS. Includes parts SVCTY121B269, SVCTY122D221.

Table with 3 columns: Ref. No., Part No., Part Name & Description. Section: COMPONENT COMBINATIONS. Includes parts EXRP203P104T, EXBP87104K, etc.

Table with 3 columns: Ref. No., Part No., Part Name & Description. Section: THERMISTERS. Includes parts ERTD2FHL103S, ERTD2FHL103S.

Table with 3 columns: Ref. No., Part No., Part Name & Description. Section: LAMP. Includes part XAMR68S8.

Table with 3 columns: Ref. No., Part No., Part Name & Description. Section: FLUORESCENT DISPLAY TUBE. Includes part SAD7MT29ZA.

Table with 3 columns: Ref. No., Part No., Part Name & Description. Section: LIQUID ELECTROLYTE DOUBIE LAYER CAPACITOR. Includes part EECW1R8A3R3S.

Table with 3 columns: Ref. No., Part No., Part Name & Description. Section: SWITCHES. Includes parts SSH537, SSH533, SSG7, SSH183, SSS43, ESB70133, ESE372.

Table with 3 columns: Ref. No., Part No., Part Name & Description. Section: FUSES. Includes parts XBA2C10TR0.

Table with 3 columns: Ref. No., Part No., Part Name & Description. Section: RESISTORS. Includes parts ERD50TJ104, ERD25TJ823, ERD50TJ184, etc.

Table with 3 columns: Ref. No., Part No., Part Name & Description. Section: RESISTORS. Includes parts ERD25TJ104, ERD25FJ822, ERD25FJ221, etc.

Table with 3 columns: Ref. No., Part No., Part Name & Description. Section: RESISTORS. Includes parts ERD25FJ331, ERD25TJ123, ERD25TJ473, etc.

Table with 3 columns: Ref. No., Part No., Part Name & Description. Section: RESISTORS. Includes parts ERD25FJ682, ERD25TJ183, ERD25FJ471, etc.

Table with 3 columns: Ref. No., Part No., Part Name & Description. Section: RESISTORS. Includes parts ERD25TJ223, ERD25FJ681, ERD25FJ103, etc.

Table with 3 columns: Ref. No., Part No., Part Name & Description. Section: RESISTORS. Includes parts ERD25FJ332, ERD25FJ102, ERD25FJ103, etc.

Table with 3 columns: Ref. No., Part No., Part Name & Description. Section: RESISTORS. Includes parts ERD25TJ104, ERD25FJ392, ERD25FJ103, etc.

Table with 3 columns: Ref. No., Part No., Part Name & Description. Section: RESISTORS. Includes parts ERD25FJ122, ERD25FJ392, ERD25FJ103, etc.

Table with 3 columns: Ref. No., Part No., Part Name & Description. Section: RESISTORS. Includes parts ERD25FJ103, ERD25CKF3301, ERD25FJ470, etc.

Table with 3 columns: Ref. No., Part No., Part Name & Description. Section: RESISTORS. Includes parts ERD25TJ223, ERD25TJ104, ERD25TJ683, etc.

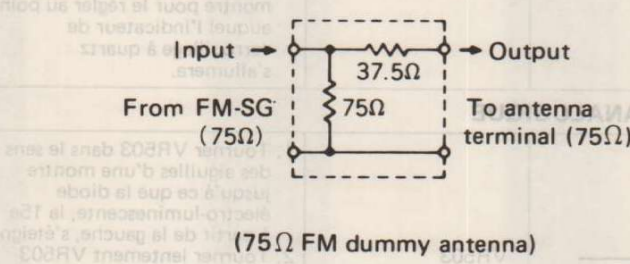

Fig. 6 (Abb. 1)

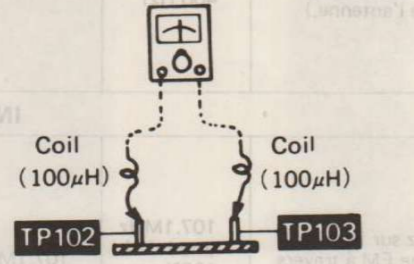

Fig. 7 (Abb. 2)

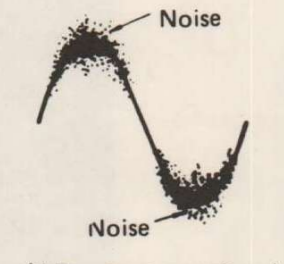

Fig. 8 (Abb. 3)

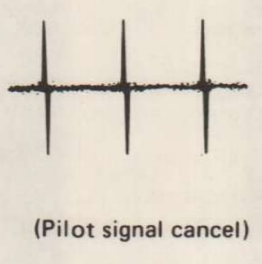
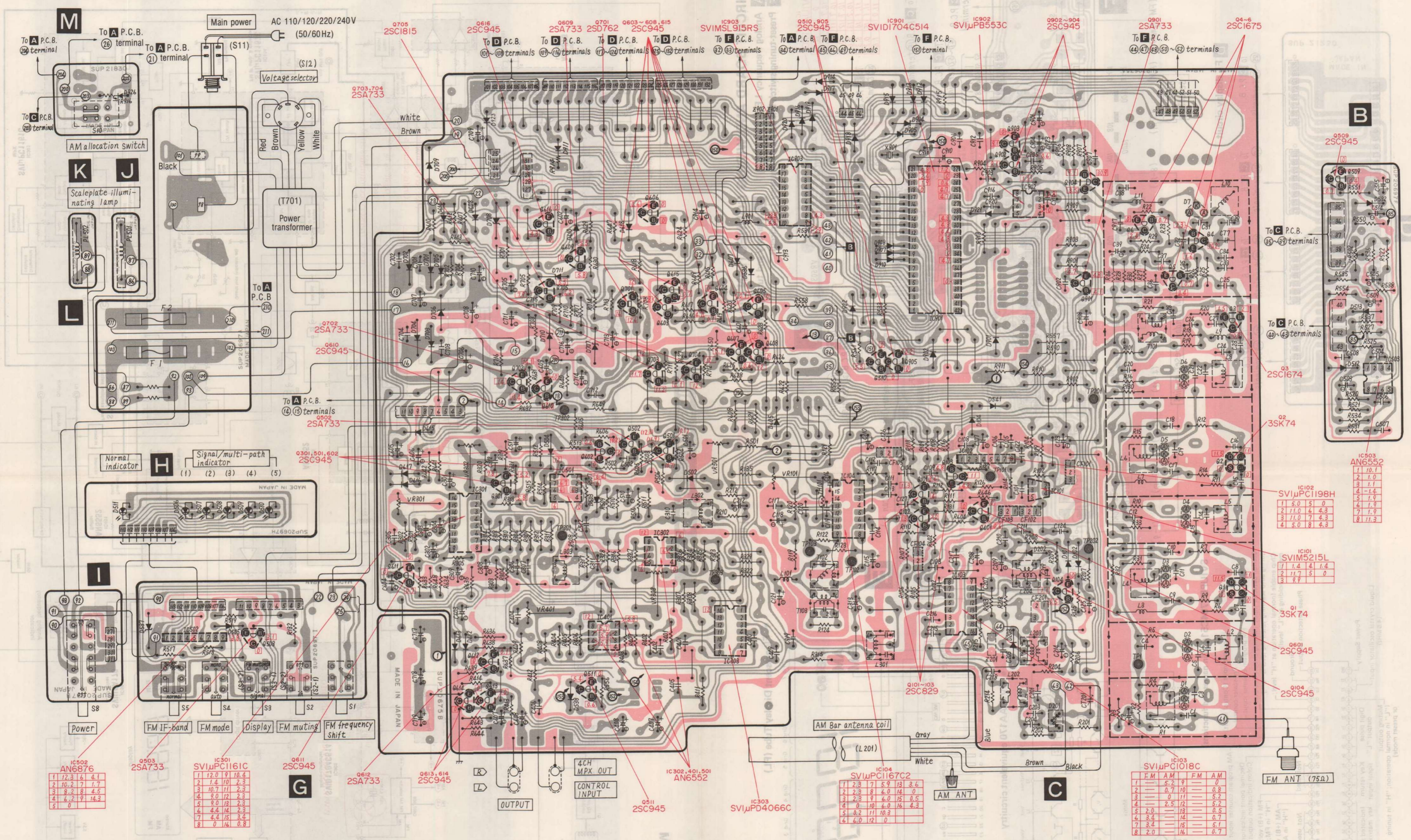

Fig. 9 (Abb. 4)

- E** FM signal-strength circuit
 C FM/AM tuner and power source circuit
 G Signal/multi-path indicator drive and switches circuit
 H Signal/multi-path indicator circuit
 I Power switch circuit
 J **K** Scale plate illuminating lamp circuit
 L Power supply circuit
 M AM allocation switch circuit



• Terminal guide of transistors and IC's

<p>3SK74</p> <p>1. Gate 1 2. Gate 2 3. Drain 4. Source</p>	<p>2SA733 2SC829 2SC945 2SC1674 2SC1675 2SC1815</p>	<p>2SD762</p>	<p>SVID1704C514</p>	<p>SVIM5215L</p>	<p>SVIμPC1198H</p>	<p>AN6876</p>	<p>SVIμPD4066C</p>	<p>SVIMSL915RS</p>	<p>AN6552 SVIμPB53C</p>	<p>SVIμPC1018C SVIμPC1161C SVIμPC1167C SVIμAA170</p>
---	---	----------------------	----------------------------	-------------------------	---------------------------	----------------------	---------------------------	---------------------------	---	--

IC503 AN6552

1	10.1
2	1.0
3	1.1
4	1.4
5	1.9
6	1.9
7	1.9
8	11.3

IC102 SVIμPC1198H

1	5.0	5.0
2	11.0	4.3
3	11.0	4.3
4	5.0	4.3

IC101 SVIM5215L

1	1.4	1.4
2	11.7	5.0
3	11.7	5.0

IC104 2SC945

IC103 SVIμPC1018C

FM	AM	FM	AM	
1	5.2	9	0.8	
2	0.7	10	0.8	
3	0	11	5.2	
4	2.0	2.5	12	5.2
5	2.0	13	0.5	
6	3.4	14	0.7	
7	3.4	15	0.1	
8	2.0	16	0.7	

CIRCUIT BOARD AND WIRING CONNECTION DIAGRAM

- A** Analog frequency LED drive circuit
- E** Memory and tuning switches circuit
- F** Preset-tuning switch and analog frequency LED circuit

Ground (Earth) lines

IC504 SVIUAA170

1	0	9	12.3
2	10.7	10	14.9
3	10.7	11	1.7
4	10.7	12	0
5	10.2	13	3.6
6	11.1	14	5.3
7	11.1	15	0.2
8	11.0	16	1.6

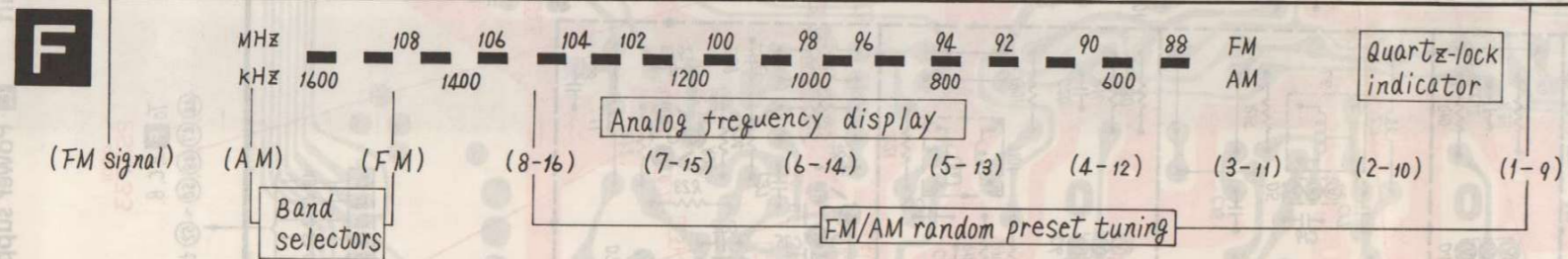
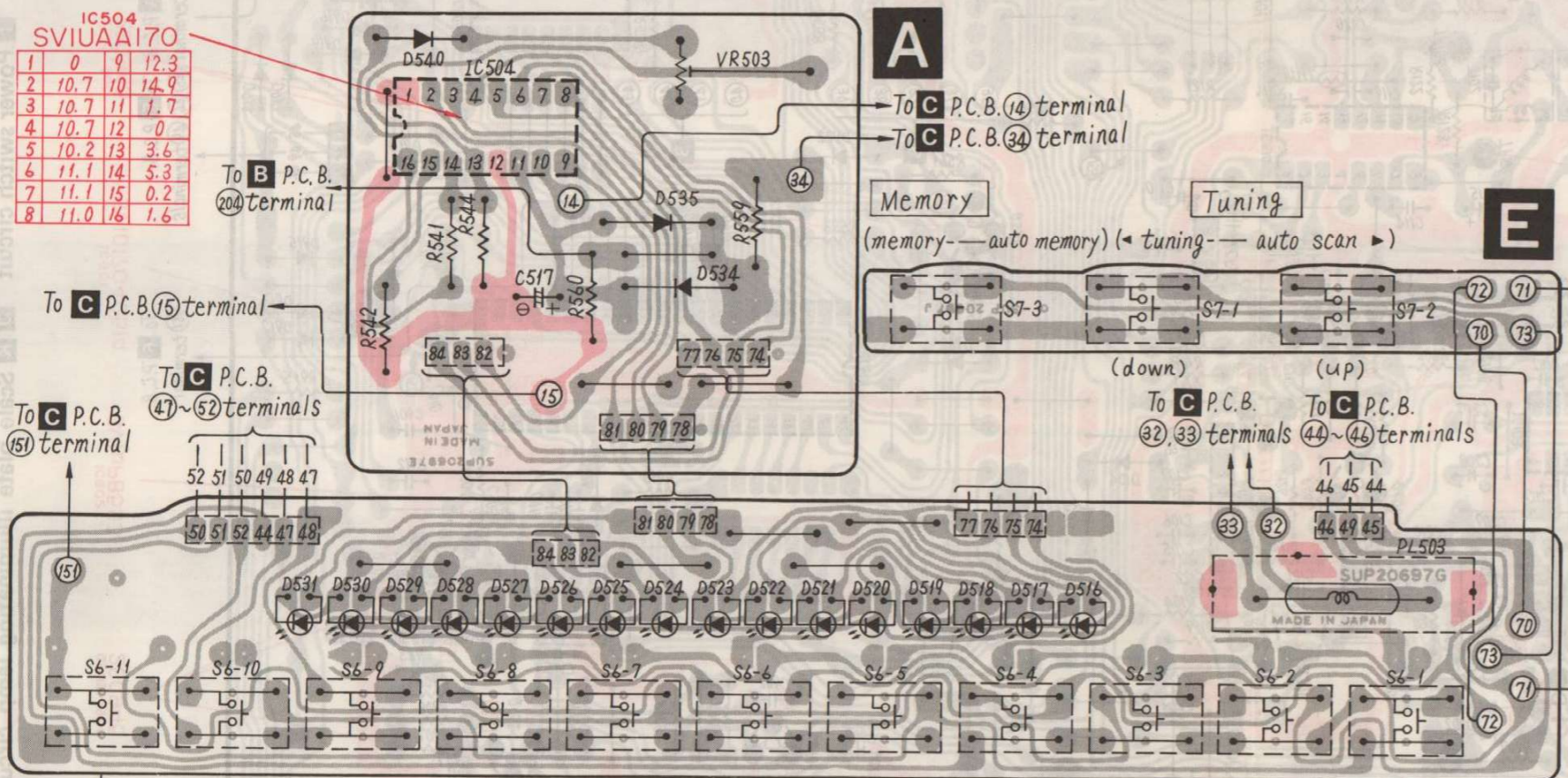

Fluorescent Display Tube (FL)

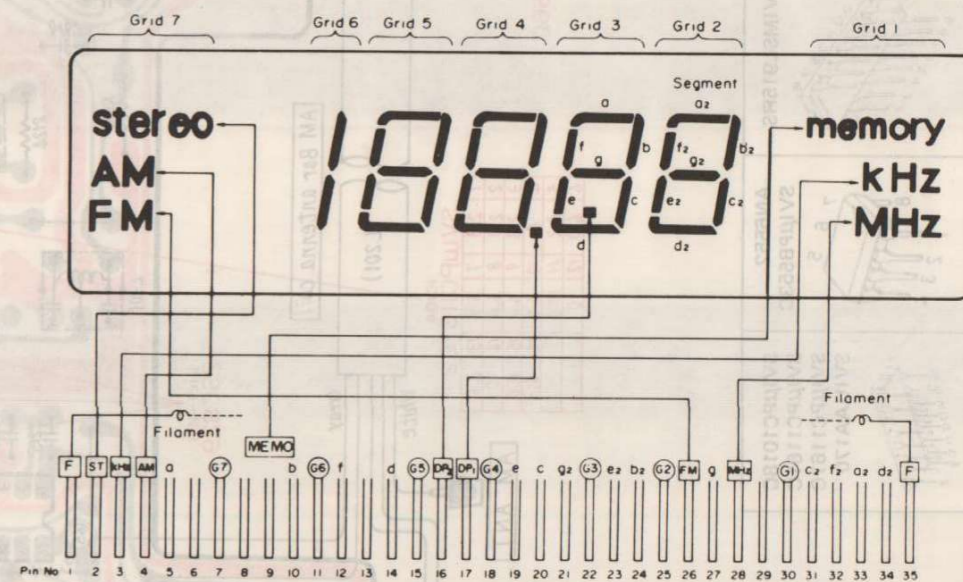

SVIUAA170 equivalent circuitry

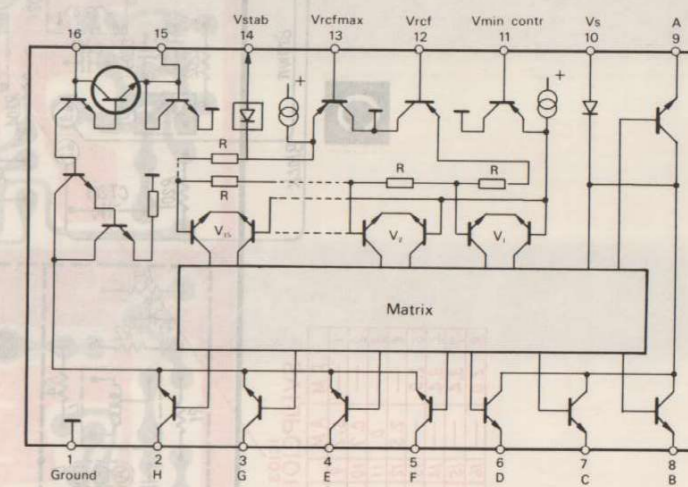

D FL display circuit

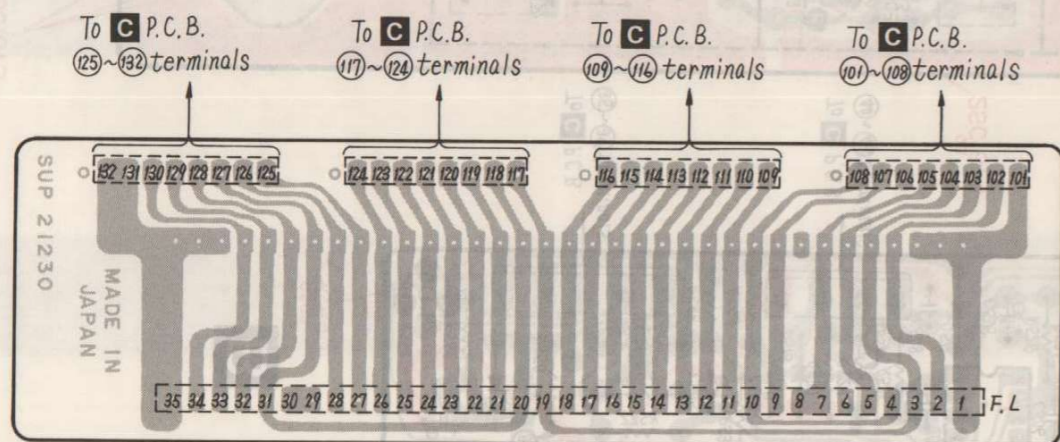

SVIUPD1704C514 (Pin names and functions)

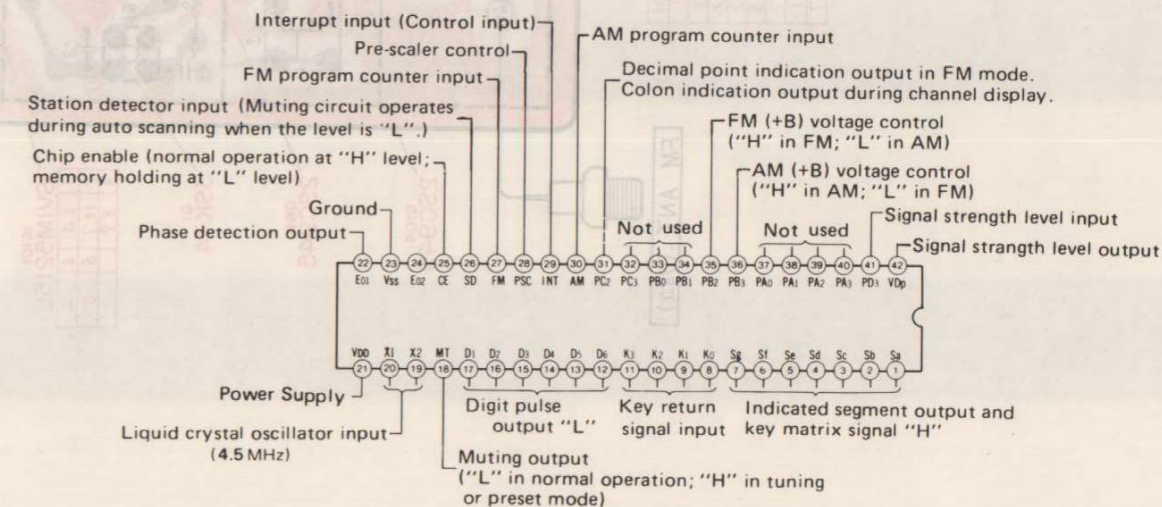

Continued from page 16

Table with columns: Ref. No., Part No., Part Name & Description. Lists various components like capacitors, resistors, and other parts.

Table with columns: Ref. No., Part No., Part Name & Description. Lists various components like capacitors, resistors, and other parts.

Table with columns: Ref. No., Part No., Part Name & Description. Lists various components like capacitors, resistors, and other parts.

Areas
* [E] is available in Switzerland and Scandinavia.
* [EG] is available in F.R. Germany.
* [EF] is available in France.
* [EH] is available in Holland.
* [EB] is available in Belgium.
* [EK] is available in United Kingdom.
* [XA] is available in Southeast Asia, Oceania, Africa, Middle Near East and Central South America.
* [XL] is available in Australia.

REPLACEMENT PARTS LIST ... (Cabinet and Chassis Parts)

Notes:
1. Part numbers are indicated on most mechanical parts. Please use this part number for parts orders.
2. Important safety notice: Components identified by Δ mark have special characteristics important for safety. When replacing any of these components, use only manufacturer's specified parts.

Table with columns: Ref. No., Part No., Part Name & Description. Lists cabinet and chassis parts like front panel, buttons, and switches.

EXPLODED VIEWS

