

# AM/FM STEREO TUNER TX-1000/U/TX-2000

## SERVICE MANUAL

15215

TX-1000/U  
/TX-2000

For Service Manuals Contact  
MAURITRON TECHNICAL SERVICES  
8 Cherry Tree Rd, Chinnor  
Oxon OX9 4QY  
Tel:- 01844-351694 Fax:- 01844-352554  
Email:- enquiries@mauritron.co.uk

### ■ CONTENTS

TO SERVICE PERSONNEL .....	1	IC BLOCK/CIRCUIT DATA .....	10 ~ 14
FRONT PANELS .....	1	WIRING .....	15
REAR PANELS .....	2, 3	BLOCK DIAGRAM .....	16, 17
SPECIFICATIONS .....	3, 4	PRINTED CIRCUIT BOARD .....	18 ~ 21
INTERNAL VIEW .....	4	REMOTE CONTROL TRANSMITTER .....	22, 23
DISASSEMBLY PROCEDURES .....	5	SCHEMATIC DIAGRAM .....	18, 19, 24
ADJUSTMENTS .....	6 ~ 10	PARTS LIST .....	25 ~ 32

100194

# YAMAHA

YAMAHA CORPORATION  
P.O. Box 1, Hamamatsu, Japan

3.7k-062  Printed in Japan '88.7

## TO SERVICE PERSONNEL

- Critical Components Information.**  
Components having special characteristics are marked  $\Delta$  and must be replaced with parts having specifications equal to those originally installed.
- Leakage Current Measurement (For 120V Model Only).**  
When service has been completed, it is imperative that you verify that all exposed conductive surfaces are properly insulated from supply circuits.

  - Meter impedance should be equivalent to 1500 ohm shunted by 0.15  $\mu$ F.
  - Leakage current must not exceed 0.5mA.
  - Be sure to test for leakage with the AC plug in both polarities.

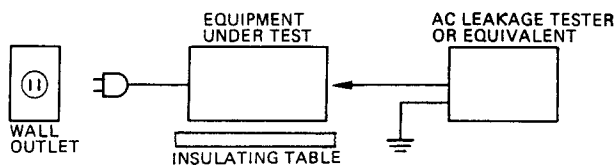

### POLARIZATION

This tuner product is equipped with a polarized alternating-current line plug (a plug having one blade wider than the other). This plug will fit into the power outlet only one way. This is a safety feature. (U, C Model only)

## FRONT PANELS

### TX-1000

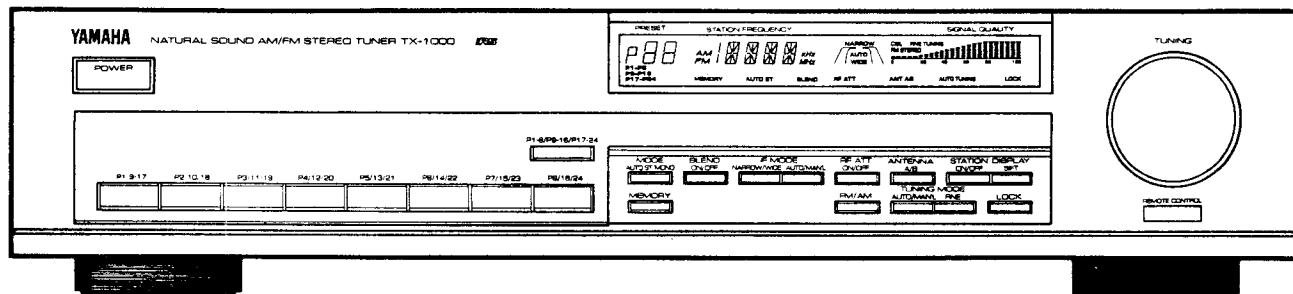

### TX-1000U

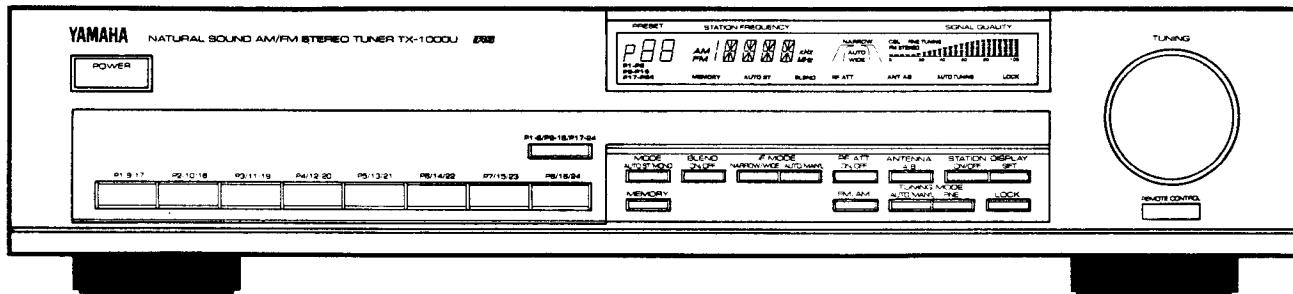

### TX-2000

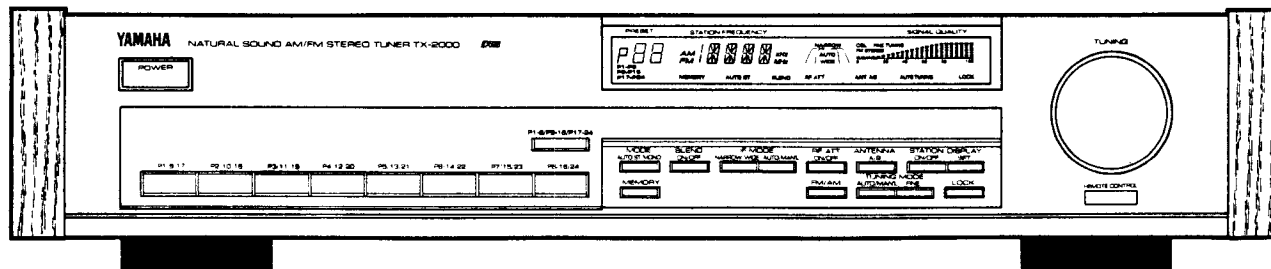

**REAR PANELS**

**TX-1000/1000U**

● U.S.A. & Canadian Model

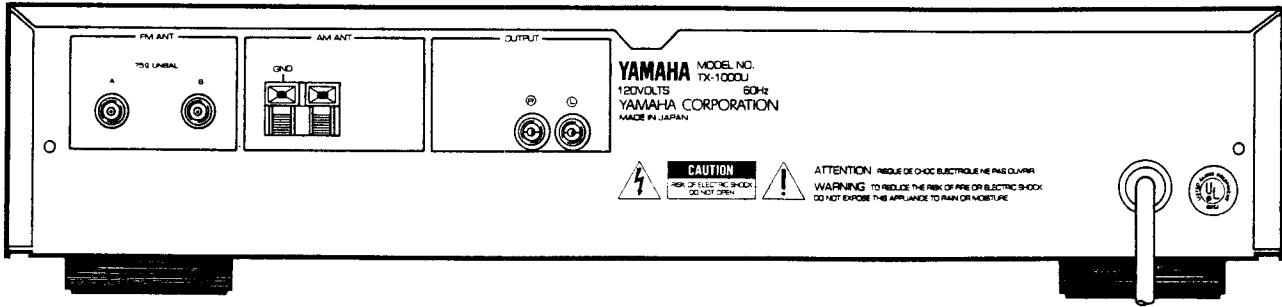

● European Model

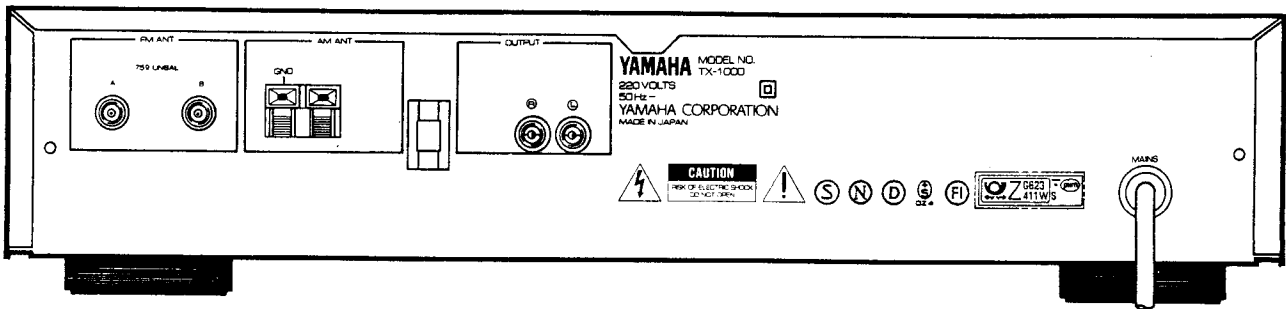

/TX-2000

● Australian & British Model

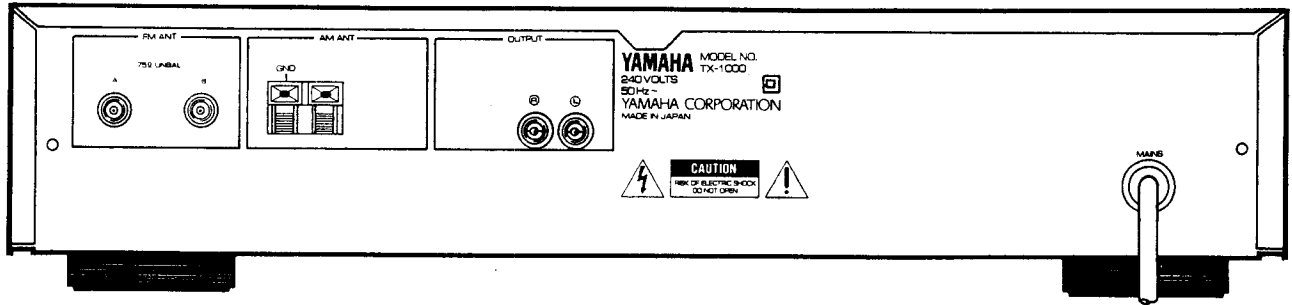

● General Model

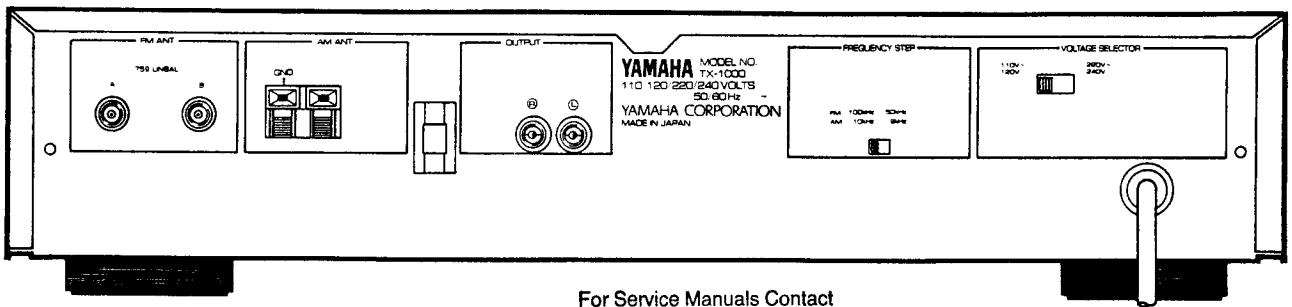

For Service Manuals Contact  
**MAURITRON TECHNICAL SERVICES**  
 8 Cherry Tree Rd, Chinnor  
 Oxon OX9 4QY  
 Tel:- 01844-351694 Fax:- 01844-352554  
 Email:- enquiries@mauritron.co.uk

**TX-2000**

● U.S.A. & Canadian Model

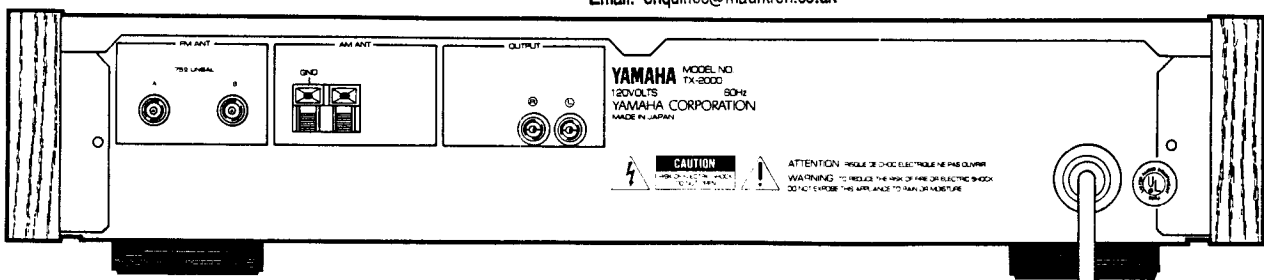

**TX-2000**

● West Germany Model

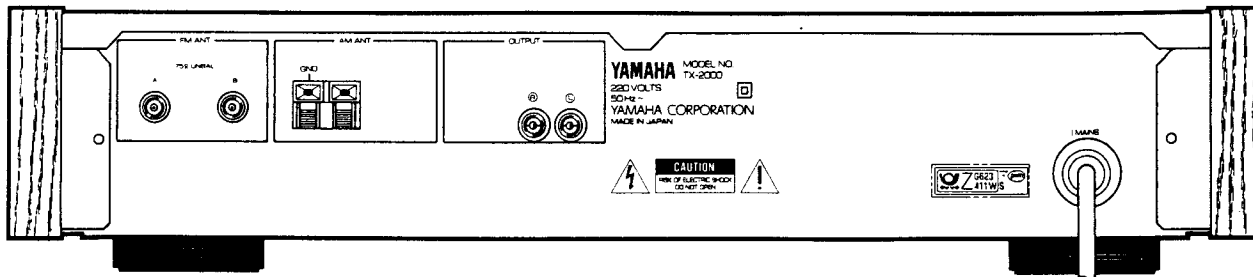

● General Model

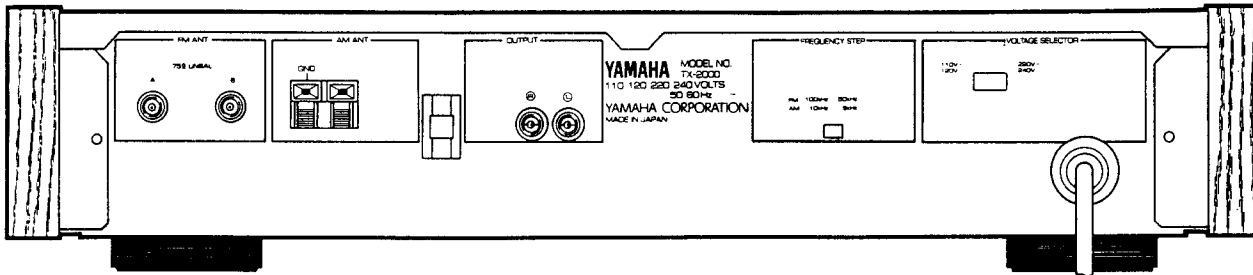

● RS-TX1000

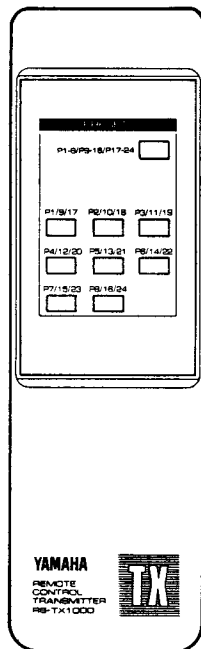

● RS-TX2000

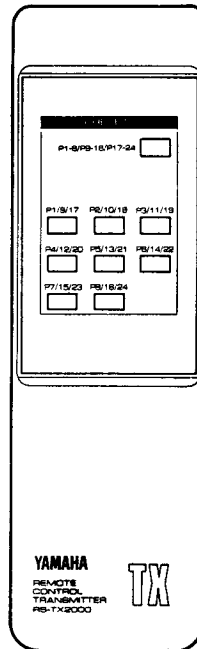

For Service Manuals Contact  
**MAURITRON TECHNICAL SERVICES**  
 8 Cherry Tree Rd, Chinnor  
 Oxon OX9 4QY  
 Tel:- 01844-351694 Fax:- 01844-352554  
 Email:- enquiries@mauritron.co.uk

**SPECIFICATIONS**

● FM Section

Tuning Range	87.6 ~ 108 MHz
50 dB Quieting Sensitivity (IHF)	
75 Ω Mono	1.6 μV (15.3 dBf)
Stereo	20 μV (37.2 dBf)
Usable Sensitivity	
30 dB S/N Quieting	0.9 μV (10.3 dBf)
Usable Sensitivity (DIN)	
75 Ω Mono (S/N 26 dB)	0.8 μV [W, G model]
Stereo (S/N 46 dB)	22 μV [W, G model]
Image Response Ratio	95 dB
IF Response Ratio	115 dB
Spurious Response Ratio	110 dB
AM Suppression Ratio	70 dB
Capture Ratio (WIDE)	1.2 dB
Alternate Channel	
Selectivity (NARROW)	90 dB [U, C, R, A, B model]
Selectivity (two Signals)	
40 kHz Dev. ± 300 kHz	80 dB

Signal to Noise Ratio (IHF)

Mono	98 dB
Stereo	90 dB

Signal to Noise Ratio

DIN NOISE RMS 40 kHz Dev.	
Mono	86 dB [W, G model]
Stereo	79 dB [W, G model]

Harmonic Distortion

WIDE 1 kHz	0.02% [U, C, R, A, B model]
WIDE 1 kHz	0.03% [U, C, R, A, B model]

Harmonic Distortion (40 kHz DEV.)

WIDE 1 kHz	0.03% [W, G model]
------------	--------------------

Stereo Separation

WIDE 1 kHz	68 dB
------------	-------

Frequency Response

50 Hz to 10 kHz	0 +0.2 -0.3 dB
20 Hz to 15 kHz	0 +0.2 -0.5 dB

Sub-Carrier Product Ratio	65 dB
---------------------------	-------

### ● AM Section

Tuning Range	520 ~ 1,620 kHz [U, C, R model]
	522 ~ 16, 20 kHz [A, B, W, G model]
Unable Sensitivity	100 $\mu$ Vm [U, C, A, B model]
	250 $\mu$ Vm [R, W, G model]
Selectivity	32 dB
Signal to Noise Ratio	52 dB
Image Response Ratio	40 dB
Spurious Response Ratio	50 dB
Harmonic Distortion	0.3%

### ● AUDIO Section

Output Level/Impedance (Fixed)	
FM 100% MOD, 1 kHz	500mV/1k $\Omega$ [U, C, R, A, B model]
	400mV/1k $\Omega$ [W, G model]
AM 100% MOD, 400 Hz	150mV/1k $\Omega$

For Service Manuals Contact  
**MAURITRON TECHNICAL SERVICES**  
 8 Cherry Tree Rd, Chinnor  
 Oxon OX9 4QY  
 Tel: 01844-351694 Fax: 01844-352554  
 Email: enquiries@mauritron.co.uk

### ● GENERAL

Power Supply	AC120V, 60 Hz [U, C model]
	AC110 ~ 120/220 ~ 240V 50/60 Hz [R model]
	AC220V, 50 Hz [W, G model]
	AC240V, 50 Hz [A, B model]
Power Consumption	15W
Dimensions (W x H x D)	
TX-1000	435 x 95 x 366.5 mm (17-1/8" x 3-47/64" x 14-27/64")
TX-2000	473 x 95.5 x 366.5 mm (18-5/8" x 3-48/64" x 14-27/64")
Weight	
TX-1000	6.1 kg (13 lbs. 7.17 oz)
TX-2000	7.2 kg (15 lbs. 13.97 oz)

(U) ... U.S.A. model	(W) ... West Germany model
(C) ... Canadian model	(G) ... European model
(A) ... Australian model	(R) ... General model
(B) ... British model	

Specifications subject to change without notice.

## INTERNAL VIEW

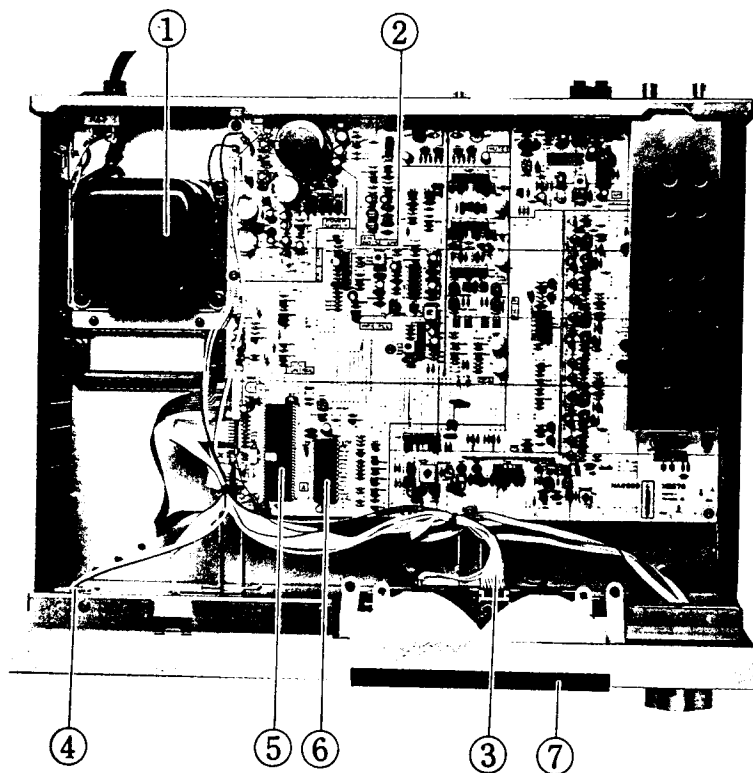

- ① POWER TRANSFORMER  
U, C Models: XE247001  
R Model: XE249001  
W, G Model: XE679001
- ② TUNER CIRCUIT BOARD
- ③ LCD CIRCUIT BOARD
- ④ POWER SWITCH=SW2
- ⑤ IC11: LC66506B-3910
- ⑥ IC12: LC7210
- ⑦ LCD UNIT

## DISASSEMBLY PROCEDURES

Step	Item	Operation
1	Top panel	Remove 4 screws ①, remove 1 screw ②, and remove 4 screws ③.
2	Panel unit	Remove 6 screws ④ and 2 rivets ⑤.
3	Rear panel	Remove 8 screws ⑦.
4	TUNER CIRCUIT BOARD (1)	Remove 7 screws ⑧.
5	TUNER CIRCUIT BOARD (2)	Remove 2 rivets ⑨.
6	LCD CIRCUIT BOARD	After removing 2 rivets ⑩, remove 2 more rivets ⑪.
7	FUNCTION CIRCUIT BOARD	Remove 3 screws ⑫.

\*Disconnect connectors and remove soldering on wiring as necessary.

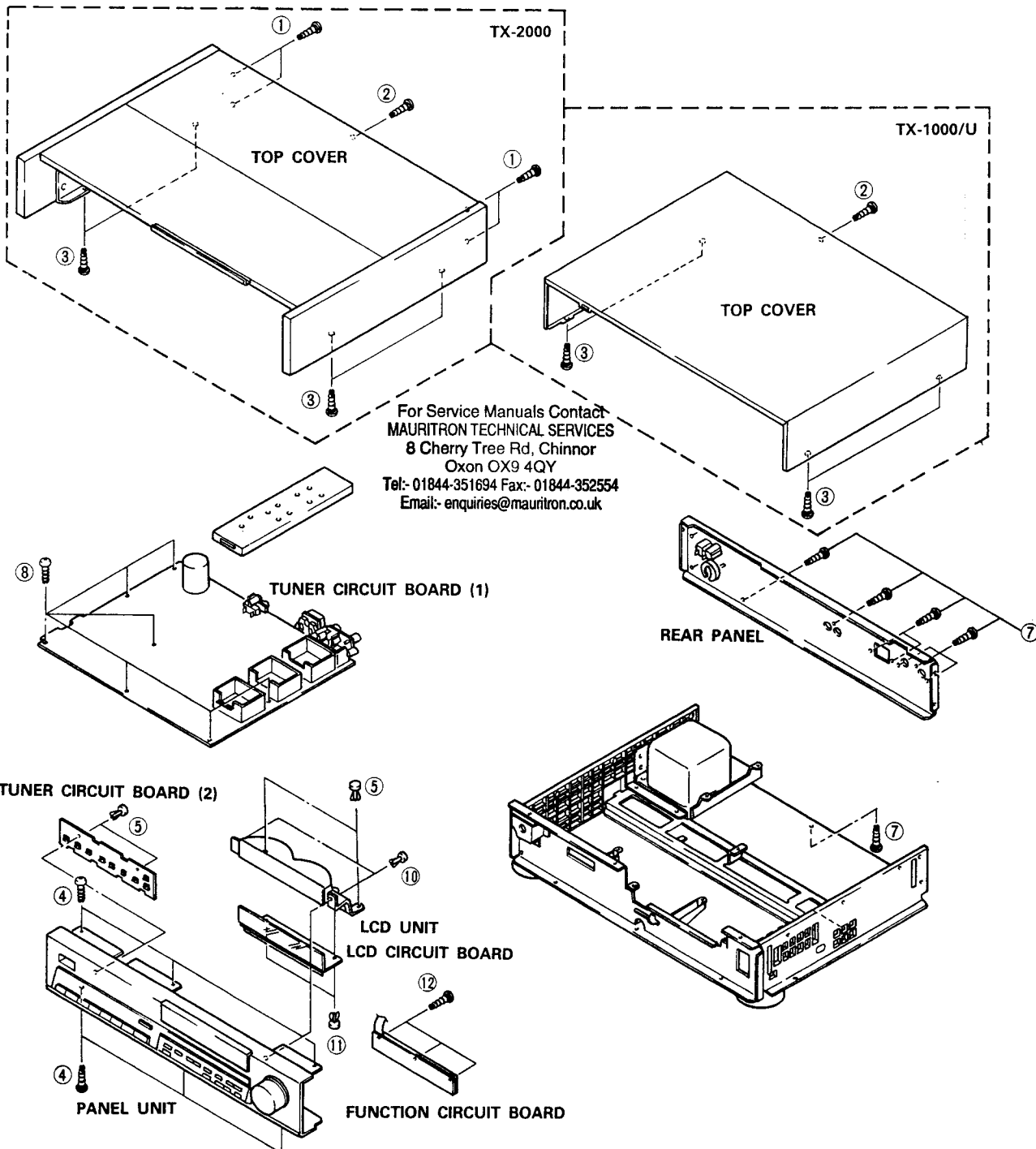

For Service Manuals Contact  
 MAURITRON TECHNICAL SERVICES  
 8 Cherry Tree Rd, Chinnor  
 Oxon OX9 4QY  
 Tel:- 01844-351694 Fax:- 01844-352554  
 Email:- enquiries@mauritron.co.uk

# ADJUSTMENTS

## ● Adjustment points

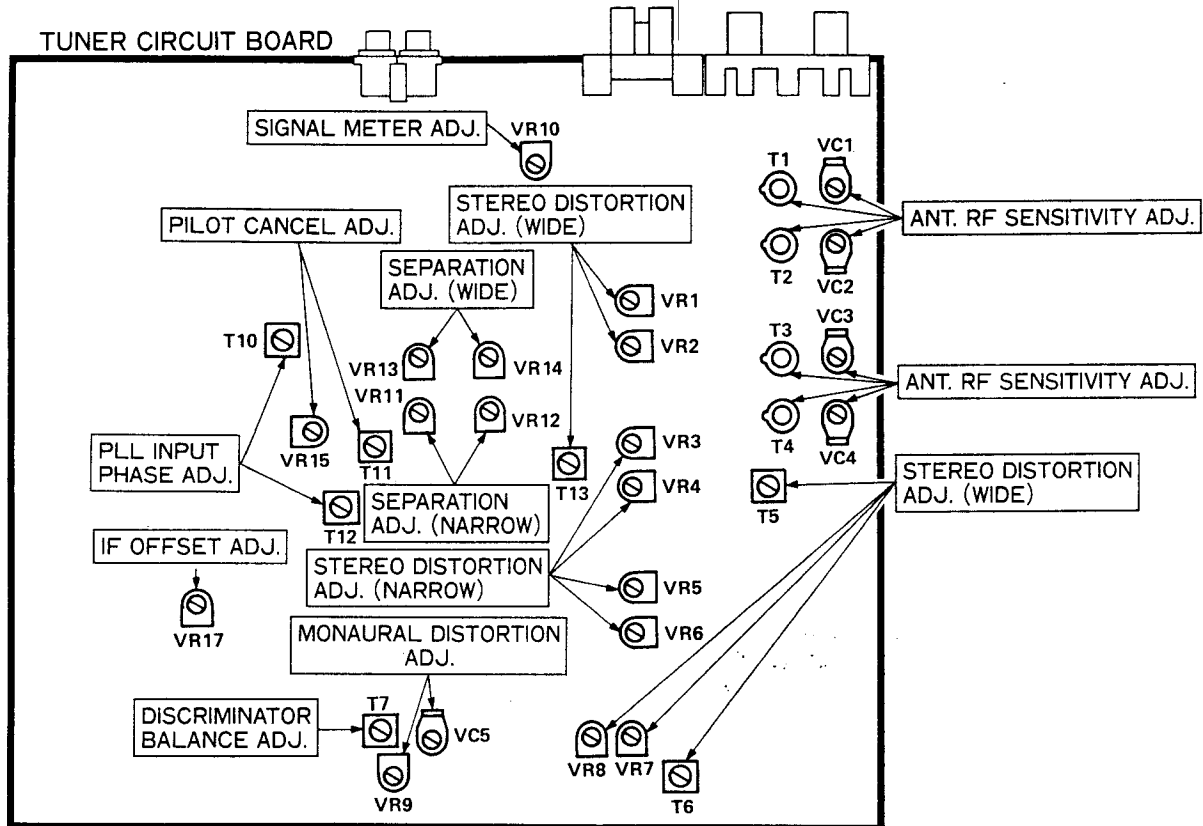

### 1. Before Adjustment

- 1) Start adjustment approximately 5 minutes after the power has been turned on in order to stabilize circuit operation.
- 2) Adjust the OSC coil and IFT using a high-frequency or nonferrous screwdriver.
- 3) Adjust the FM section first, then adjust the AM section.
- 4) Set the switches to the following positions unless otherwise specified.  
 MODE ..... AUTO ST  
 BLEND ..... OFF  
 IF MODE ..... AUTO WIDE  
 RF ATT ..... OFF  
 ANTENNA ..... A
- 5) Be sure to carry out adjustments after installing the bottom cover.

### 2. POWER SUPPLY Check

Confirm that the voltages specified below appear across each terminal and E of the TUNER CIRCUIT BOARD.

Terminal	Voltage	Measuring instrument
+30	+29 ±1V	DCVM
+12	+12.5 ±0.5V	
-12	-12.5 ±0.5V	
+6	+6V ±0.5V	

### 3. Measuring Instruments

- FM SG ..... FM Signal Generator
- ST SG ..... Stereo Signal Generator
- AM SG ..... AM Signal Generator
- OSC ..... Oscillator
- DIST M ..... Distortion Meter
- FC ..... Frequency Counter
- AC VM ..... AC Voltmeter
- Center Meter ..... Ji00036 or equivalent
- DC VM ..... DC Voltmeter

### 4. FM Tuner Section

- Use 19kHz LPF for output terminals and carry out auditory compensation. Then connect the oscilloscope, AC voltmeter and distortion meter.
- To check the optimum tuning point during adjustment, connect the tuning meter (Ji00036 or equivalent; current sensitivity: 250uA) as shown in the figure.
- The accuracy of FM SG should be within ±1kHz.

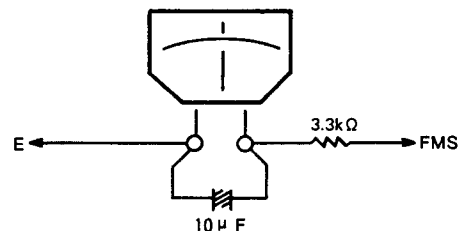

TX-2000

Step	Adjustment item	Test point	Instrument (signal)	Adjustment location	Adjustment method	Rating or standard	Remarks
1	ANT, RF sensitivity adjustment	<ul style="list-style-type: none"> <li>● ANT A</li> <li>● Output terminals</li> </ul>	<ul style="list-style-type: none"> <li>● FM SG</li> <li>● ST SG</li> <li>● DIST. M</li> <li>● OSC</li> </ul>	VC1~VC4 T1~T4	<ul style="list-style-type: none"> <li>● Adjust VC1~VC4 for maximum sensitivity at 106MHz.</li> <li>● Adjust T1~T4 for maximum sensitivity at 88MHz.</li> </ul>	less than 4dB $\mu$ [U, C, R, A, B, model] less than 6dB $\mu$ [W, G model]	
2	Discriminator balance adjustment	<ul style="list-style-type: none"> <li>● FMS</li> <li>● E</li> </ul>	<ul style="list-style-type: none"> <li>● TUNING METER</li> </ul>	T7	<ul style="list-style-type: none"> <li>● In autotuning mode, adjust T7 so that the needle of the tuning meter does not move from zero (center).</li> </ul>		
3	Monaural distortion adjustment	300 $\Omega$ FM ANT Output terminals	FM SG 98.1MHz $\pm$ 1kHz 70dB $\mu$ MONO 100Hz 100% Mod. DIST. M, OSC L.P.F	VC5 VR9	Reduce distortion to minimum.	-66dB or less	Reception should be made in WIDE mode.
4	PLL input phase adjustment	300 $\Omega$ FM ANT Output terminals L, R	FM SG 98.1MHz $\pm$ 1kHz 70dB $\mu$ STEREO (L-R) 1kHz 100% Mod. OSC	T10 T12	Increase output to maximum.		Reception should be made in WIDE mode.
5	Stereo distortion adjustment (WIDE)	300 $\Omega$ FM ANT Output terminals L, R	FM SG, ST SG 98.1MHz $\pm$ 1kHz 70dB $\mu$ STEREO (L-R) 1kHz 100% Mod. OSC	T5, 6, 13 VR1, 2, 7, 8	Reduce distortion to minimum.	-56dB or less	Reception should be made in WIDE mode. After adjustment, reconfirm sensitivity and disk rebalance. If they are not within the specifications, go back to the step before adjustment and reconfirm again.
	Stereo distortion adjustment (NARROW)	300 $\Omega$ FM ANT Output terminals L, R	FM SG, ST SG 98.1MHz $\pm$ 1kHz 70dB $\mu$ STEREO L, R 1kHz 100% Mod. DISTM, OSC, LPF	VR3, 4, 5, 6	Reduce distortion to minimum.	-33dB or less	Reception should be made in NARROW mode. After adjustment, reconfirm sensitivity and disk rebalance. If they are not within the specifications, go back to the step before adjustment and reconfirm again.
6	Monaural distortion check	300 $\Omega$ FM ANT Output terminals	FM SG 98.1MHz $\pm$ 1kHz 70dB $\mu$ MONO 1kHz 100% Mod.		Confirm that monaural distortion is within the specification.	-56dB or less	Reception should be made in WIDE mode.
7	Separation adjustment (WIDE)	300 $\Omega$ FM ANT Output terminals L, R	FM SG, ST SG 98.1MHz $\pm$ 1kHz 70dB $\mu$ STEREO L, R 1kHz 100% Mod. OSC, AC VM LPF	VR13, 14	Increase L $\rightarrow$ R, R $\rightarrow$ L channel separation to maximum.	Separation 40dB or more	Reception should be made in NARROW mode.
	Separation adjustment (NARROW)	300 $\Omega$ FM ANT Output terminals L, R		VR11, 12			

For Service Manuals Contact  
**MAURITRON TECHNICAL SERVICES**  
 8 Cherry Tree Rd, Chinnor  
 Oxon OX9 4QY  
 Tel:- 01844-351694 Fax:- 01844-352554  
 Email:- enquiries@mauritron.co.uk

Step	Adjustment item	Test point	Instrument (signal)	Adjustment location	Adjustment method	Rating or standard	Remarks
8	Pilot cancel adjustment (WIDE)	300Ω FM ANT Output terminals L, R	FM SG, ST SG 98.1MHz ± 1kHz 70dB $\mu$ Pilot signal 9% modulation only Remove LPF OSC, AC VM	VR15, T11	Measure with an oscilloscope; reduce 19kHz carrier leakage level to minimum.	-50dB or less	
9	Discriminator balance check	300Ω FM ANT	FM SG, ST SG 98.1MHz ± 1kHz Antenna input -10dB $\mu$ STEREO L, R 1kHz 30% Mod.		In autotuning mode, confirm that the needle of the tuning meter does not move from zero.		If unsatisfactory, return to Step 1 and readjust.
10	Signal meter adjustment	300Ω FM ANT	FM SG, ST SG 98.1MHz ± 1kHz Antenna input 80dB $\mu$ STEREO L, R 1kHz 30% Mod.	VR10	Adjust VR10 so that the needle of the tuning meter moves to 100.		Reception should be made in WIDE mode
11	Blend check	300Ω FM ANT	FM SG, ST SG 98.1MHz ± 1kHz 70dB $\mu$ STEREO L, R 1kHz 100% Mod.		With the BLEND switch on, confirm that separation deteriorates.		Reception should be made in WIDE mode.
12	IF OFFSET adjust	300Ω FM ANT D4-K3 short-circuited	FM SG, ST SG 98.1MHz ± 1kHz Antenna input 70dB $\mu$ No Mod.	VR17	Adjust VR17 so that 10kHz shifts 1 digit to 0 or 1.		CSL reception.
13	Autotuning check	300Ω FM ANT D4-K3 left open	FM SG, ST SG 98.1MHz ± 1kHz Antenna input 15dB $\mu$ [W model: 18dB $\mu$ ] 1kHz, 30% Mod.	TUNING knob	Turn the TUNING knob and confirm that autotuning is available.		Audio muting occurs during switching from IF MODE to AUTO TUNING.
14	RF ATT check	300Ω FM ANT	FM SG, ST SG 98.1MHz ± 1kHz Antenna input 20dB $\mu$ Mono 1kHz 100% Mod.	RF ATT Switch	Confirm that reception sensitivity deteriorates when the RF ATT switch is on by visual monitoring of the output wave form.		
15	ANTENNA check	ANT A	FM SG, ST SG 98.1MHz ± 1kHz Antenna input 20dB $\mu$ Mono 1kHz 100% Mod.	ANTENNA Switch	Confirm that the unit enters the detuning mode when the ANTENNA switch is switched to B. Confirm that the unit enters the detuning mode when the ANTENNA switch is switched to A.		ANT B indicator lights up.
		ANT B					Confirm that the unit enters the detuning mode when the ANTENNA switch is switched to B. Confirm that the unit enters the detuning mode when the ANTENNA switch is switched to A.

For Service Manuals Contact  
**MAURITRON TECHNICAL SERVICES**  
 8 Cherry Tree Rd, Chinnor  
 Oxon OX9 4QY  
 Tel:- 01844-351694 Fax:- 01844-352554  
 Email:- enquiries@mauritron.co.uk

## 1. (AM Tuner Section Adjustment)

- Connect the AM loop antenna to the AM ANT terminals.
- Connect the AM dummy used for adjustment to AM SG.
- The accuracy of AM SG should be within  $\pm 0.1\text{kHz}$ .

Step	Adjustment item	Test point	Instrument (signal)	Adjustment location	Adjustment method	Rating or standard	Remarks
1	Sensitivity check IFT adjustment	<ul style="list-style-type: none"> <li>● AM ANT</li> <li>● GND</li> <li>● Output terminals L, R</li> </ul>	AM SG, dummy ANT. OSC, DIST M 630kHz $\pm$ 0.1kHz 1080kHz $\pm$ 0.1kHz 1440kHz $\pm$ 0.1kHz 400Hz, 30% Mod.	P9 P10 P11	Adjust T9 and increase output to maximum.	58dB $\mu$ or less 58dB $\mu$ or less 58dB $\mu$ or less	
2	Signal meter check	<ul style="list-style-type: none"> <li>● AM ANT</li> <li>● GND</li> <li>● Output terminals L or R</li> </ul>	<ul style="list-style-type: none"> <li>● AM SG</li> <li>● OSC. DIST M</li> </ul> 1080kHz $\pm$ 0.1kHz Antenna 100dB $\mu$ 400Hz, 30% Mod.		Confirm that all indicators light up (and go out when detuned).		
3	Autotuning check	<ul style="list-style-type: none"> <li>● AM ANT</li> <li>● GND</li> <li>● Output terminals L, R</li> </ul>	<ul style="list-style-type: none"> <li>● AM SG</li> <li>● OSC. DIST M</li> </ul> 1080kHz $\pm$ 0.1kHz Antenna 100dB $\mu$ 400Hz, 30% Mod.		Turn the TUNING knob and confirm that autotuning is available.		

## (Digital Control Section Check)

Step	Item	Method	Rating or Standard
1.	Preset memory check	Tune in to FM98.1 MHz and store the following settings in Preset Memory 1 (P1): MODE ..... AUTO ST BLEND ..... OFF IF MODE ..... AUTO RFATT ..... OFF ANTENNA ..... A STATION DIS ..... OFF TUNING MODE ..... AUTO	The MEMORY IND should flash when the MEMORY switch is on; when preset memories 1-8 are on, P1-8 indicators should flash. When P1 is on, the MEMORY IND and P1-8 indicators should go out and the P1 indicator light up.
		2. Tune to AM1080kHz and store in P2.	The MEMORY IND should flash when the MEMORY switch is pressed. When P2 is pressed the MEMORY IND should go out and the P2 indicator light up.
		3. Confirm that the settings stored in P1 and P2 appear when P1 and P2 buttons are pressed.	Both P1 and P2 should light up.
		4. Store the settings in 2 in P9.	P9-16 indicators should flash when the P9-16 memory switches are pressed. The MEMORY IND should flash when the MEMORY switch is pressed. When P9 is on P9-16 indicators should light up, the MEMORY indicator go out, and the P9 indicator light up.
		5. After pressing all the other preset memory buttons except P9, press P9 and confirm that stored settings appear.	
2.	MODE check	Confirm that the unit selects forced monaural reception when the unit is set to FM stereo reception and MONO is selected.	Stereo IND goes out.
3.	LOCK check	Confirm that the frequency does not change when the TUNING knob is turned when the STATION DISPLAY is off and the LOCK switch is pressed.	LOCK IND lights up.

For Service Manuals Contact  
 MAURITRON TECHNICAL SERVICES  
 8 Cherry Tree Rd, Chinnor  
 Oxon OX9 4QY  
 Tel: 01844-351694 Fax: 01844-352554  
 Email: enquires@mauritron.co.uk

Step	Item	Method	Rating or Standard
4.	IF MODE check	Confirm that the unit automatically switches to MAN'L when the setting stored in P1 are recalled, the AUTO/MAN'L switch is set to AUTO, and the NARROW/WIDE switch is pressed. Also, confirm that the display changes as these modes are changed. Finally, confirm that the unit switches to NARROW from AUTO WIDE reception as antenna input is gradually reduced.	
5.	FINE TUNING check	Confirm that the FINE TUNING IND lights up (*) when the FINE switch is pressed after recalling the settings stored in P1 and P2, and confirm that the display changes to FM 10kHz and AM 1kHz when the TUNING knob is turned.	*At this time, a zero is displayed in the area where "10kHz" should be, with FM reception (except for A, B and W, G).
6.	STATION DISPLAY check	..... is displayed when the STATION DISPLAY switch is turned on. When tuning with the unit in either the AUTO or MAN'L modes, the first digit will flash and the letter "A" is displayed when the SIFT button is pressed next. When the TUNING knob is turned to the right the display will change to A, B, C ..... when the TUNING knob is turned to the left the display will change to A, O, 9, 8 ..... The second digit will flash and the letter "A" will be displayed when the SIFT button is pressed after selecting the desired letter. Confirm that the letter stored in the memory is displayed when the desired letters for all 4 digits have been selected and recalled from the memories in which they have been stored.	
7.	Last station function check	<ol style="list-style-type: none"> <li>1. Display preset memory settings.</li> <li>2. Turn the power off.</li> <li>3. Turn the power off for 5 seconds; then turn the power on again.</li> <li>4. Confirm that the settings stored in the preset memory are displayed.</li> </ol>	P1 indicator lights up.
8.	Remote control function check	Confirm that the special remote control device that comes with the unit can switch between preset memories 1-8/9-16/17-21 and can directly select the station settings stored in preset memories P1/9/17-P8/16/24 Confirm that the RS remote control device (custom code 7A, 7E) can switch between P1-8/9-16/17-24 and can directly up-/down-select the station settings stored in P1/9/17-P9/16/24.	Distance should be 7minch or more (conduct test in an area free of obstacles).

For Service Manuals Contact  
**MAURITRON TECHNICAL SERVICES**  
 8 Cherry Tree Rd, Chinnor  
 Oxon OX9 4QY  
 Tel:- 01844-351694 Fax:- 01844-352554  
 Email:- enquiries@mauritron.co.uk

**IC BLOCK/CIRCUIT DATA**

● **IC1:  $\mu$ PC577HEF**  
(3-STAGE, IF AMP & LIMITER)

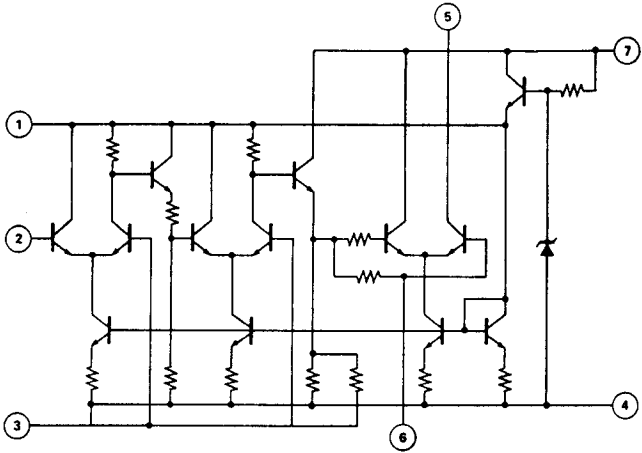

● **IC2: M54459L**  
(1/20, 1/100 DIVISION)

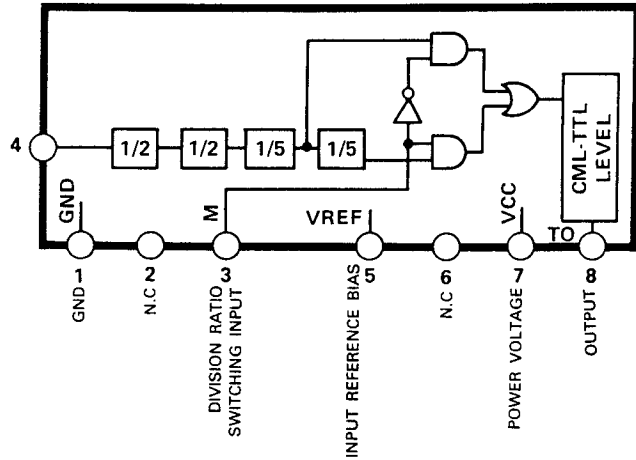

● **IC3 ~ 6, 10: NJM2068S**  
(DUAL OPE-AMP.)

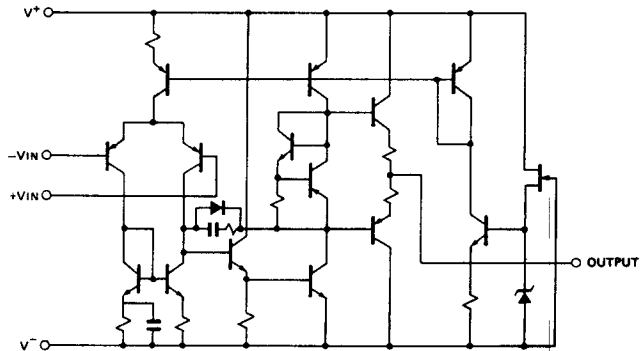
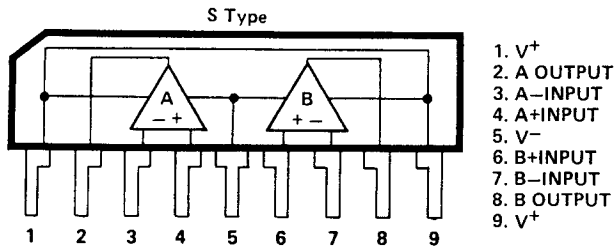

For Service Manuals Contact  
**MAURITRON TECHNICAL SERVICES**  
8 Cherry Tree Rd, Chinnor  
Oxon OX9 4QY  
Tel:- 01844-351694 Fax:- 01844-352554  
Email:- enquiries@mauritron.co.uk

● **IC7: LA1266**  
(AM/FM RF, IF AMP.)

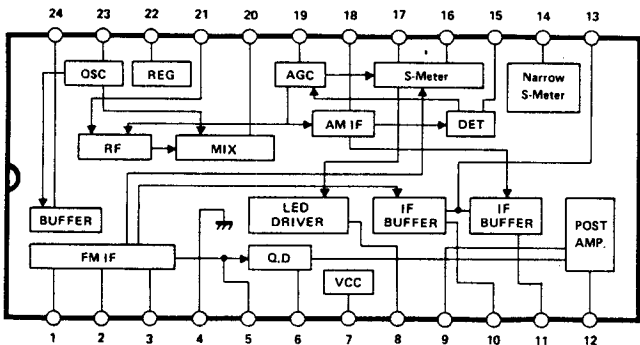

● **IC8: NJM4558S**  
(DUAL OPE-AMP.)

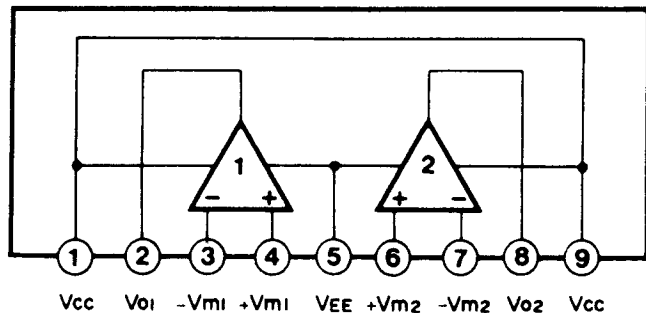

● IC9: LA3433  
(FM STEREO DEMODULATION IC)

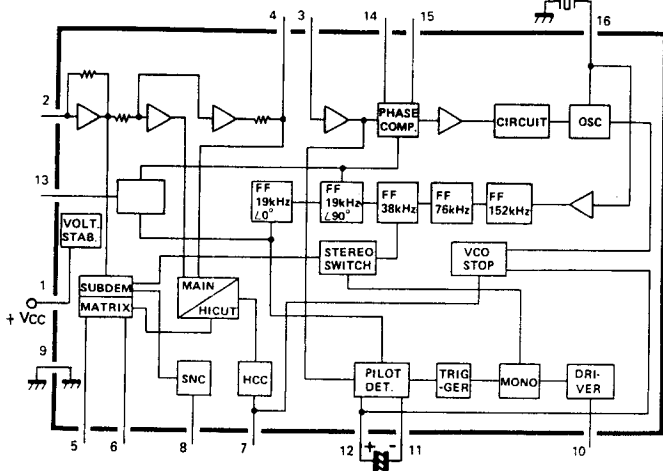

● IC12: LC7210  
(C-MOS TUNING CONTROL LSI)

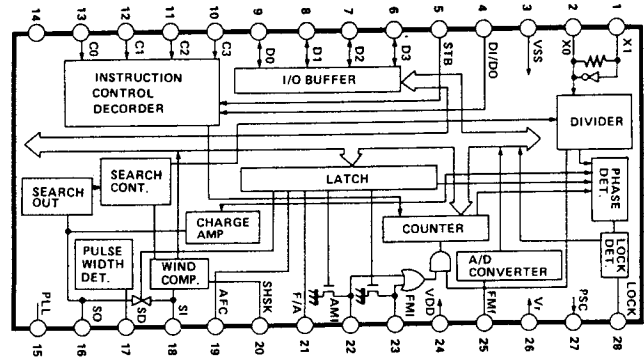

● IC501: LC7582  
(LCD DRIVER)

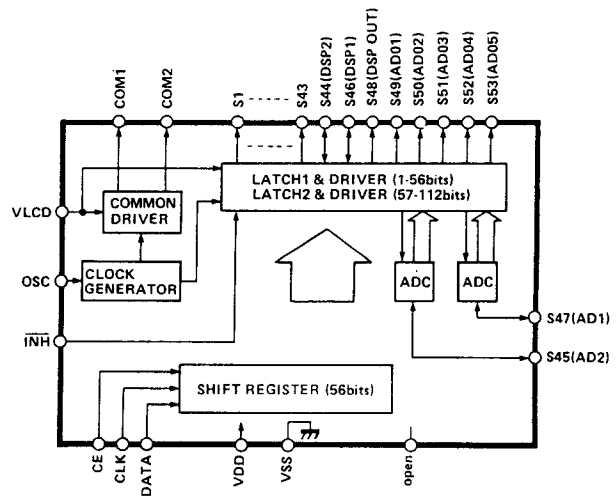
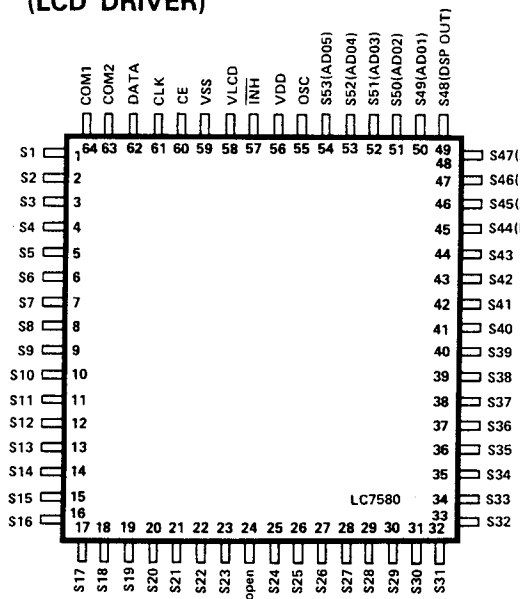

● IC502: LC7583  
(LCD DRIVER)

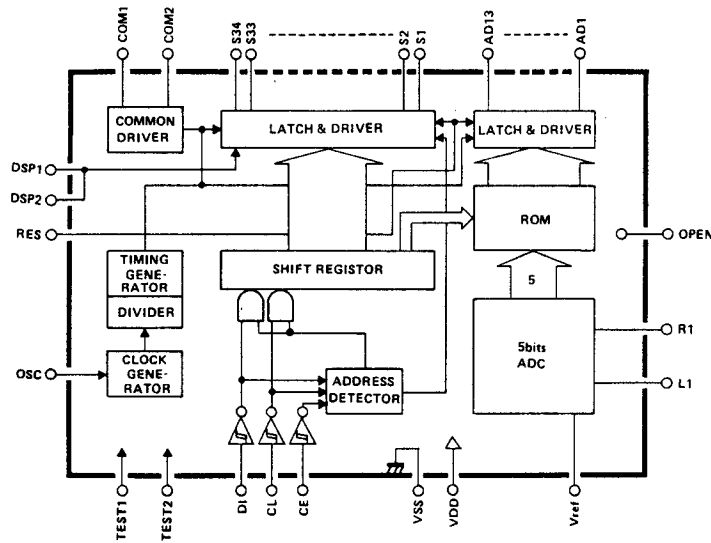

For Service Manuals Contact  
MAURITRON TECHNICAL SERVICES  
8 Cherry Tree Rd, Chinnor  
Oxon OX9 4QY  
Tel:- 01844-351694 Fax:- 01844-352554  
Email:- enquiries@mauritron.co.uk

**TX-1000/U/TX-2000**

**● IC11: LC66506B-3910(C-MOS 4 bit MICRO COMPUTER)**

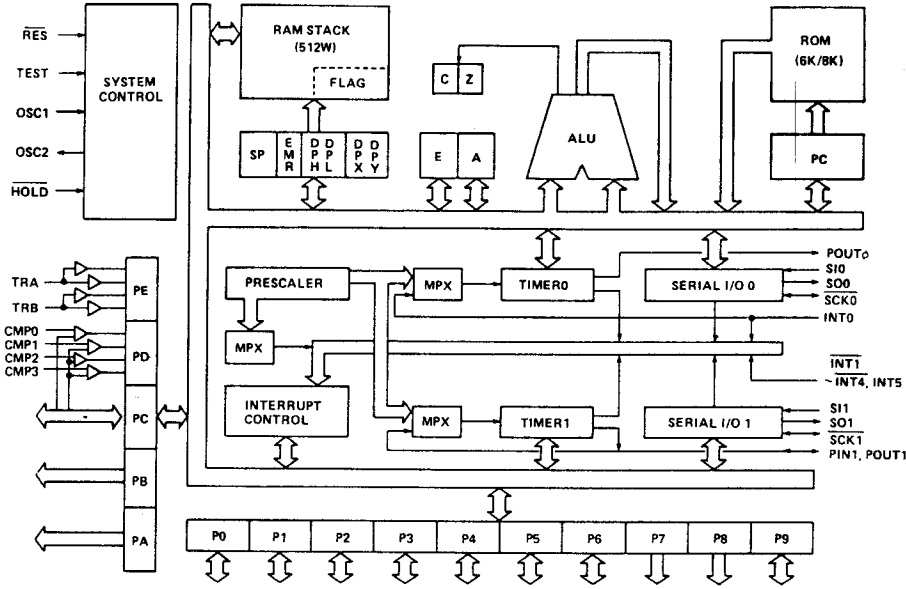
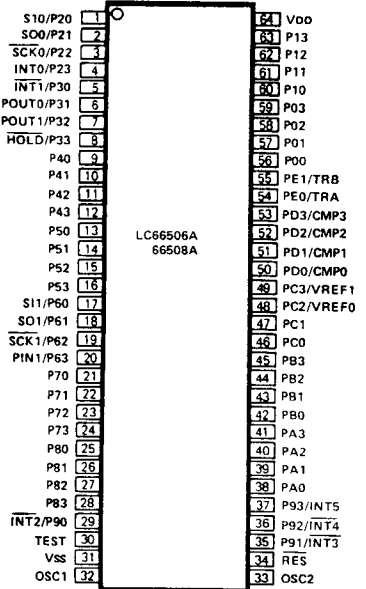

Pin No.	Description	Data	I/O	Option		Pin No.	Description	Data	I/O	Option	
				PU/OD (PO/OD)	RESET H/L					PU/OD (PD/OD)	RESET H/L
1	P20/S10	C <sub>0</sub>	O	OD		33	OSC2				
2	P21/S00	C <sub>1</sub>	O	OD		34	RES	RESET	I	-	
3	P22/SCK0	C <sub>2</sub>	O	OD		35	P91/INT3				
4	P23/INT0	C <sub>3</sub>	O	OD		36	P92/INT4				
5	P30/INT1					37	P93/INT5				
6	P32/POUT0					38	PA0	D1	O	OD	
7	P32/POUT1	STEREO IN	I	OD		39	PA1	D2	O	OD	
8	P33/HOLD	HOLD	I	-		40	PA2	D3	O	OD	
9	P40	D <sub>0</sub>	I/O	PU		41	PA3	D4	O	OD	
10	P41	D <sub>1</sub>	I/O	PU		42	PB0	D5	O	OD	
11	P42	D <sub>2</sub>	I/O	PU		43	PB1	D6	O	OD	
12	P43	D <sub>3</sub>	I/O	PU		44	PB2				
13	P50	STB	O	OD		45	PB3				
14	P51	I/O	O	OD		46	PC0	K1	I	OD	
15	P52					47	PC1	K2	I	OD	
16	P53					48	PC2/VREF0	K3	I	OD	
17	P60/SI1	BLEND	O	OD		49	PC3/VREF1	K4	I	OD	
18	P61/SO1	WIDE/NARROW	O	OD		50	PD0/CMP0				
19	P62/SCK1	RF	O	OD		51	PD1/CMP1				
20	P63/PIN1	ANT A/B	O	OD		52	PD2/CMP2	REM0	I	OD	
21	P70	A/D	O	PU		53	PD3/CMP3	REM1	I	OD	
22	P71	MUTE	O	OD		54	PE0/TRA	UP	I	OD	
23	P72	METER MUTE	O	OD		55	PE1/TRB	DOWN	I	OD	
24	P73	MONO	O	OD		56	P00	A0	I	PU	"L"
25	P80					57	P01	A1	I	PU	
26	P81				"H"	58	P02	CE(LC7582)	O	PU	
27	P82					59	P03	CE(LC7583)	O	PU	"L"
28	P83					60	P10	CLK	O	PU	
29	P90/INT2					61	P11	DATA	O	PU	
30	TEST					62	P12	INH	O	PU	
31	Vss					63	P13				
32	OSC1					64					

For Service Manuals Contact  
**MAURITRON TECHNICAL SERVICES**  
 8 Cherry Tree Rd, Chinnor  
 Oxon OX9 4QY  
 Tel: 01844-351694 Fax: 01844-352554  
 Email: enquiries@mauritron.co.uk

● LCD: LCD8003MOJP

● SEGMENT

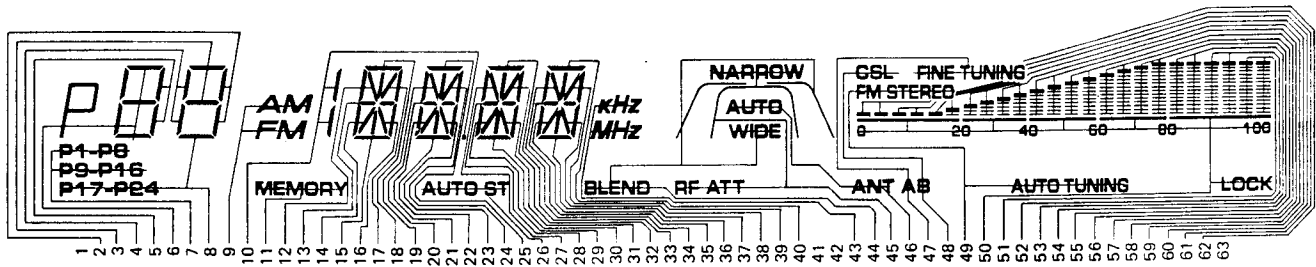

● COMMON

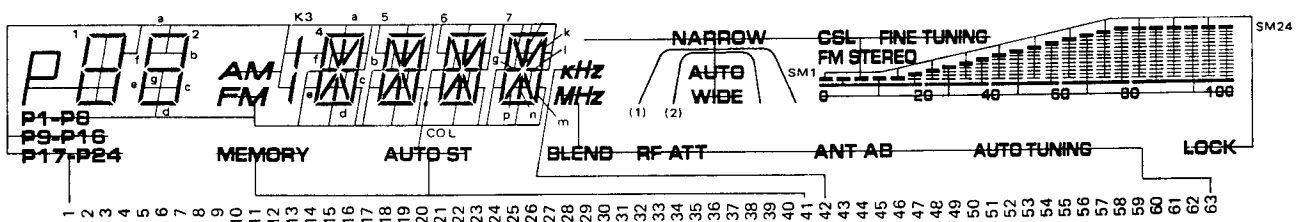

NO.	1	2	3	4	5	6	7	8	9	10	11	12	13	14	15	16	17	18	19	20	21
COM1	COM	2b	2a	2f	1b	P	P9-P16	P17-P24	AM	K3	—	4f	4l	4p	4n	4m	4b	4a	5f	5l	5p
COM2	—	2c	2g	2e	1c	1adeg	P1-P8	2d	FM	COL	MEMORY	4h	4g	4e	4d	4c	4k	4j	5h	5g	5e

No.	22	23	24	25	26	27	28	29	30	31	32	33	34	35	36	37	38	39	40	41
COM1	5n	5m	5b	5a	—	6f	6l	6p	6n	6m	6b	6a	7f	7l	7p	7n	7m	7b	7a	—
COM2	5d	5c	5k	5j	AUTO ST	6h	6g	6e	6d	6c	6k	6j	7h	7g	7e	7d	7c	7k	7j	COM

NO.	42	43	44	45	46	47	48	49	50	51	52	53	54	55	56	57	58	59	60	61	62	63
COM3	COM	kHz	WIDE (1)	NARROW (2)	AUTO	FINE TUNING	CSL	FM STEREO	LOCK	SM23	SM21	SM19	SM17	SM15	SM13	SM11	SM9	SM7	SM5	SM3	SM1	—
COM4	—	MHz	BLEND	RF ATT	ANT	A	B	AUTO TUNING	0-100	SM24	SM22	SM20	SM18	SM16	SM14	SM12	SM10	SM8	SM6	SM4	SM2	COM

For Service Manuals Contact  
**MAURITRON TECHNICAL SERVICES**  
 8 Cherry Tree Rd, Chinnor  
 Oxon OX9 4QY  
 Tel:- 01844-351694 Fax:- 01844-352554  
 Email:- enquiries@mauritron.co.uk

/TX-2000

■ WIRING

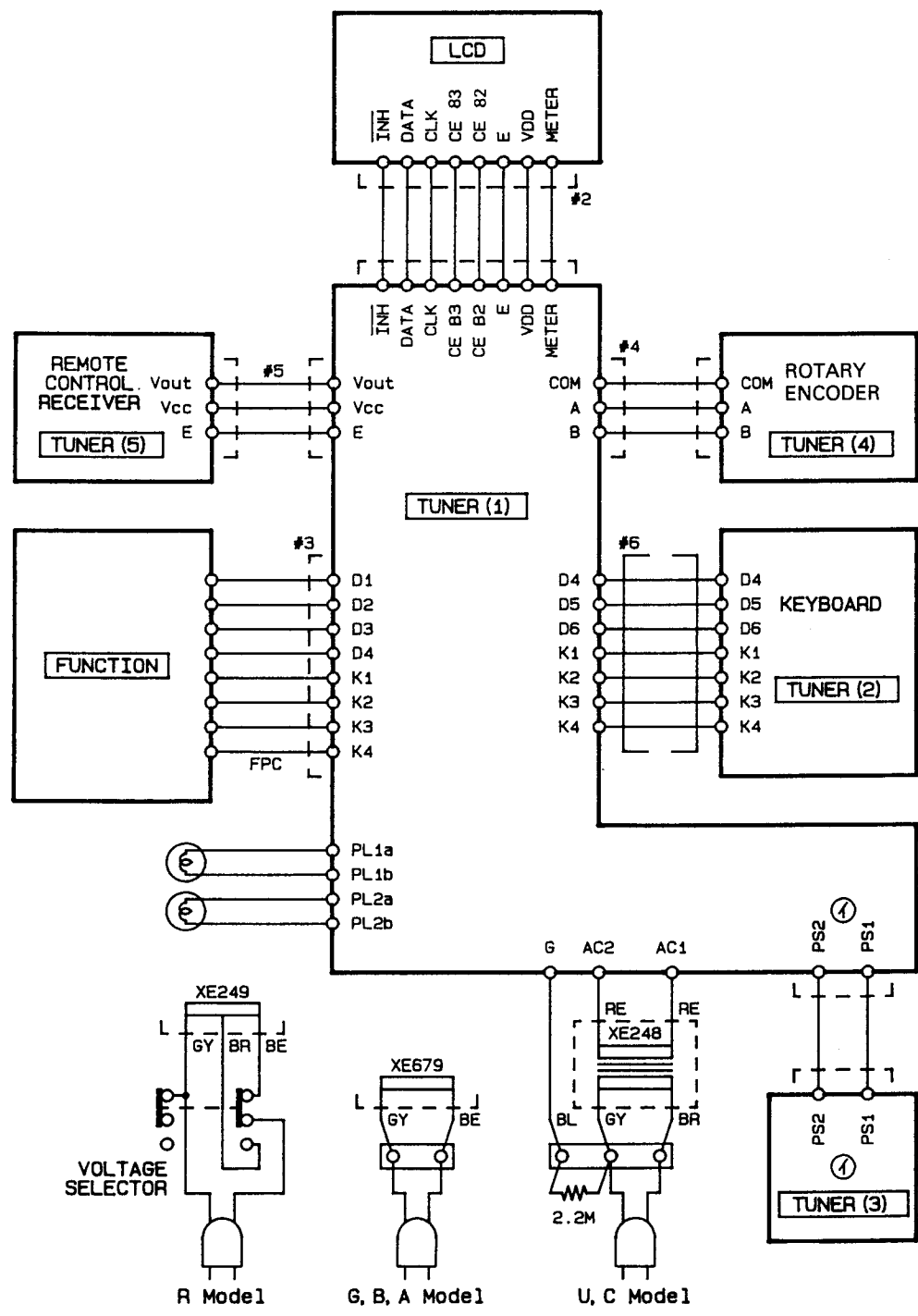

For Service Manuals Contact  
**MAURITRON TECHNICAL SERVICES**  
 8 Cherry Tree Rd, Chinnor  
 Oxon OX9 4QY  
 Tel:- 01844-351694 Fax:- 01844-352554  
 Email:- enquiries@maurifron.co.uk

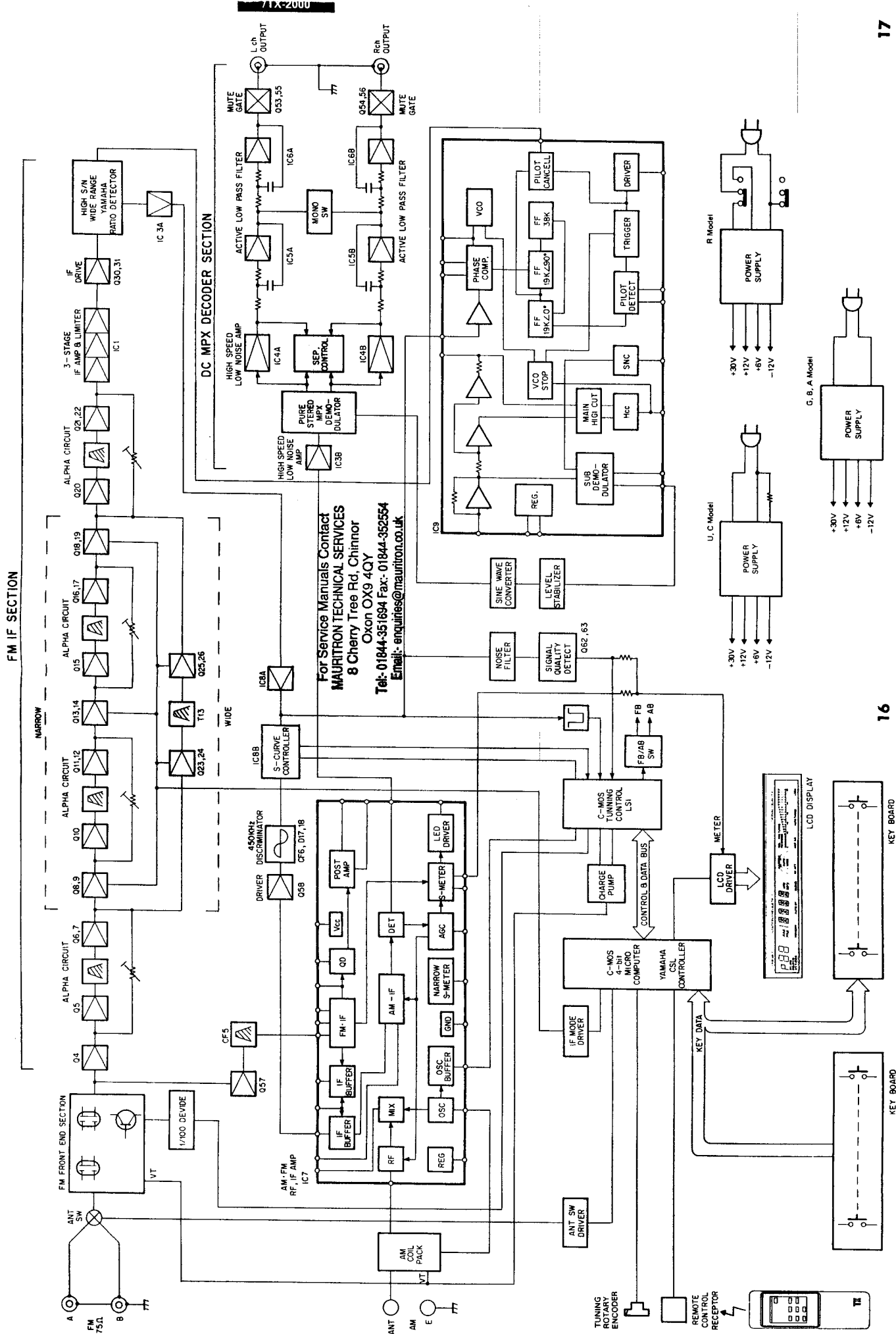

For Service Manuals Contact  
**MAURITRON TECHNICAL SERVICES**  
 8 Cherry Tree Rd, Chinnor  
 Oxon OX9 4QY  
 Tel: 01844-351694 Fax: 01844-352554  
 Email: enquiries@mauritron.co.uk

TX-1000/U/TX-2000

PRINTED CIRCUIT BOARD (Pattern Side)

1

TO TUNER  
CIRCUIT BOARD (1)

LCD CIRCUIT BOARD

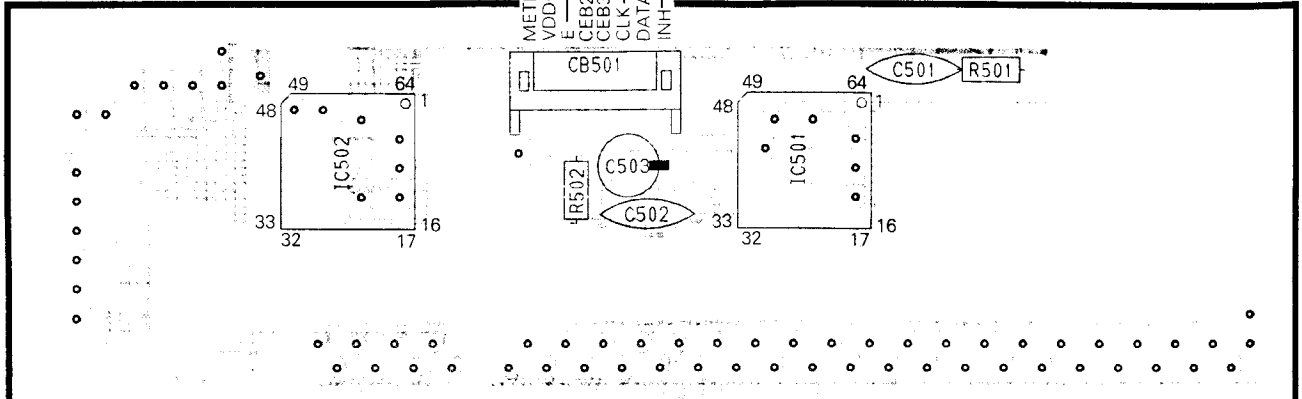

63 60 50 40 30 20 10 1

LCD

2

3

For Service Manuals Contact  
**MAURITRON TECHNICAL SERVICES**  
 8 Cherry Tree Rd, Chinnor  
 Oxon OX9 4QY  
 Tel:- 01844-351694 Fax:- 01844-352554  
 Email:- enquiries@mauritron.co.uk

4

LCD CIRCUIT BOARD

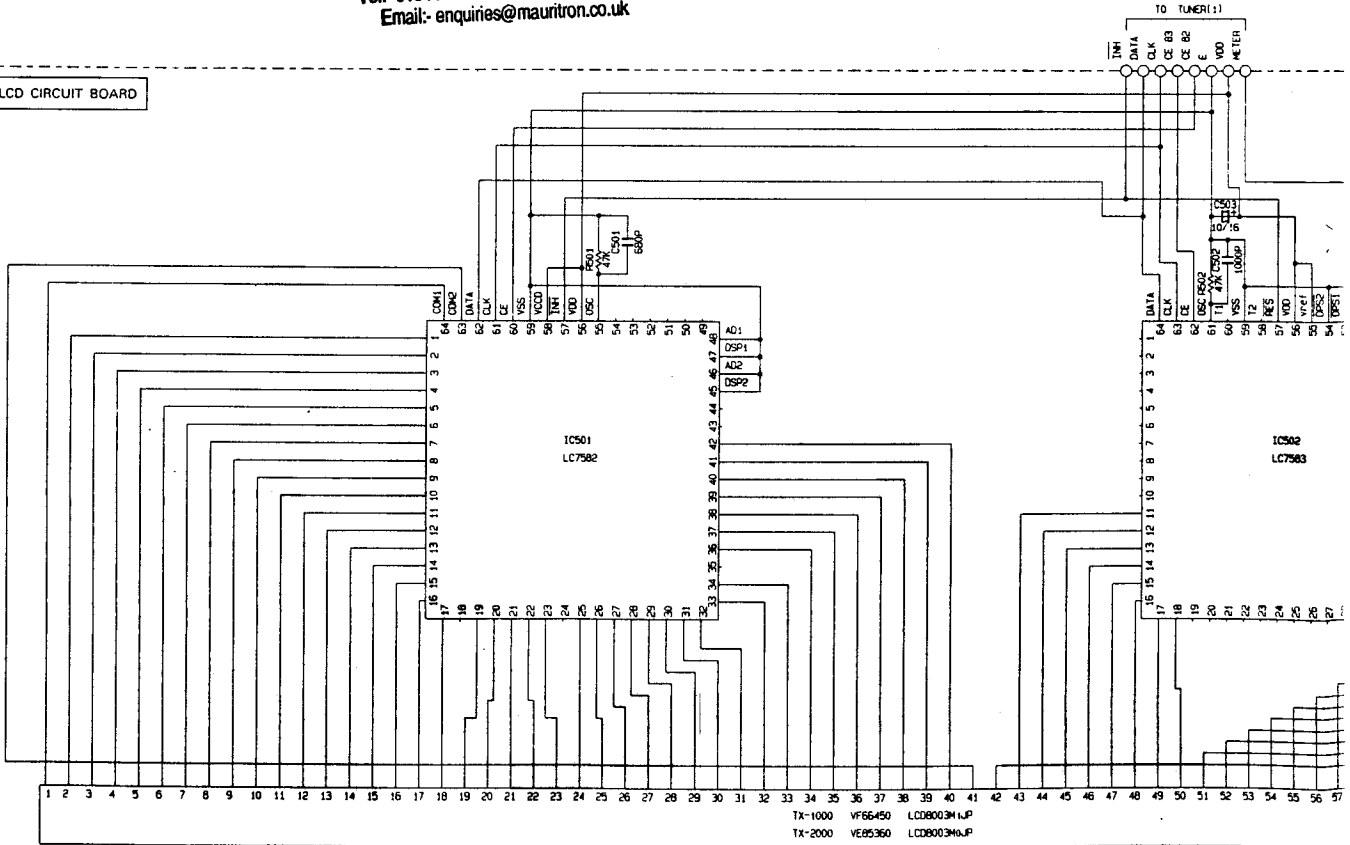

5

6

TX-1000 VF56450 LCD8003M1,P  
 TX-2000 VE85360 LCD8003M1,P

7

ARD (Pattern Side)

※ 文字面 : Component Side

# LCD CIRCUIT BOARD

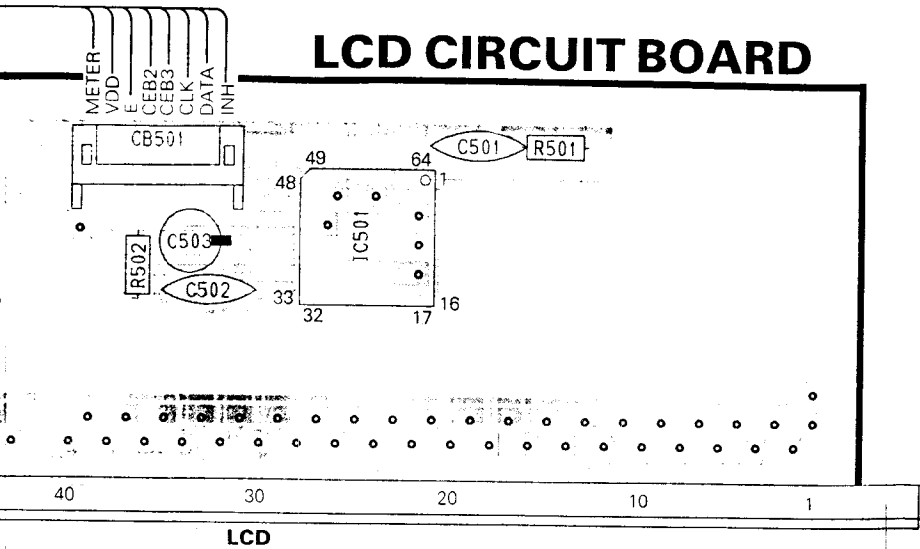

LCD

# FUNCTION CIRC

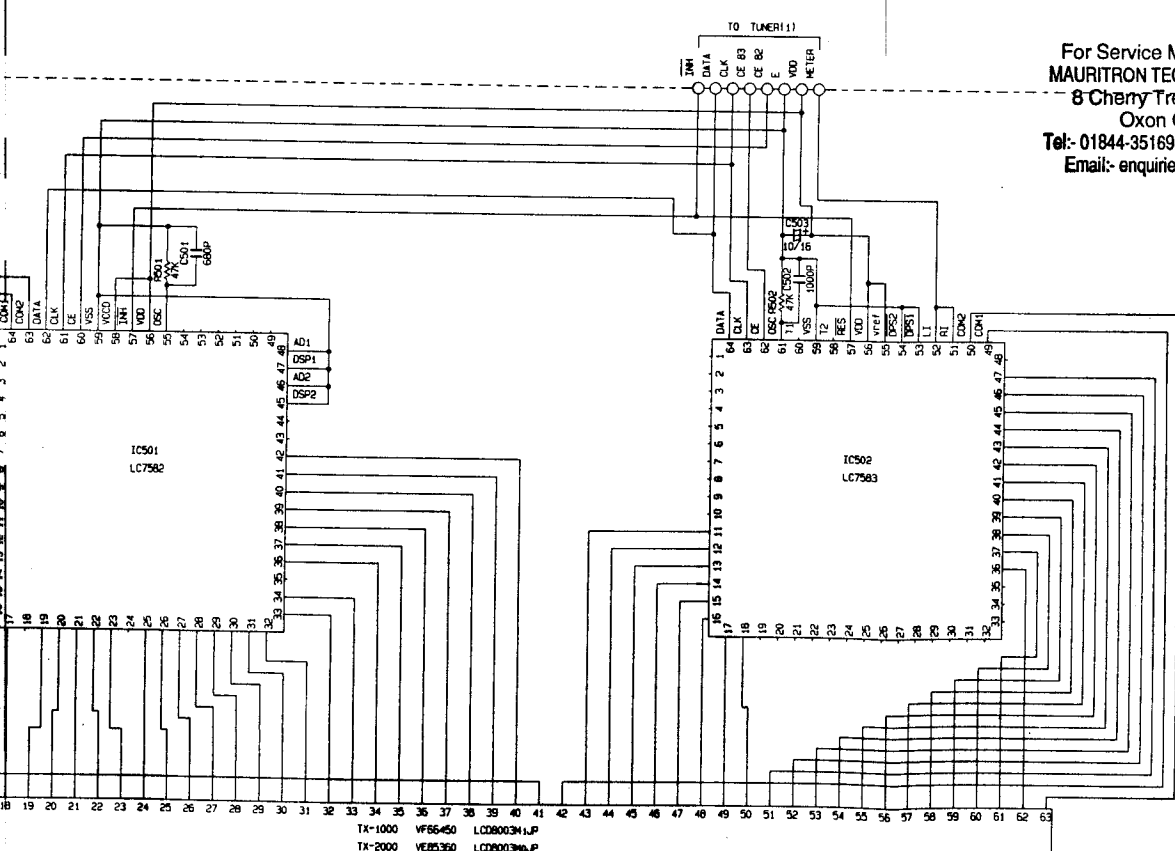
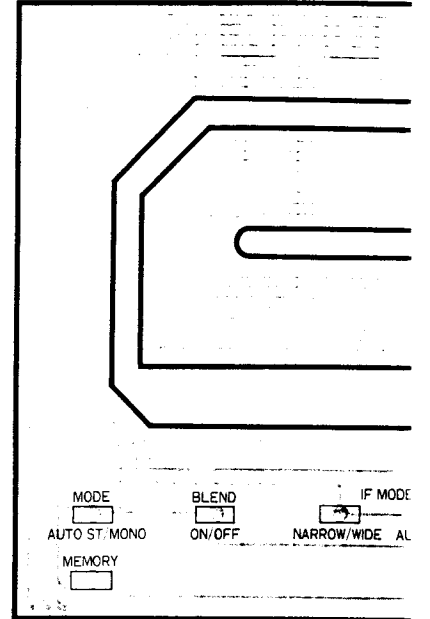

For Service Manuals Contact  
**MAURITRON TECHNICAL SERVICES**  
 8 Cherry Tree Rd, Chinnor  
 Oxon OX9 4QY  
 Tel:- 01844-351694 Fax:-01844-352554  
 Email:- enquiries@mauritron.co.uk

### FUNCTION CIRCUIT BOARD

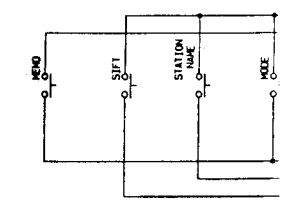

TX-1000 VF56450 LC08003M1.P  
 TX-2000 VE85360 LC08003M0.P

文字面 : Component Side

# FUNCTION CIRCUIT BOARD

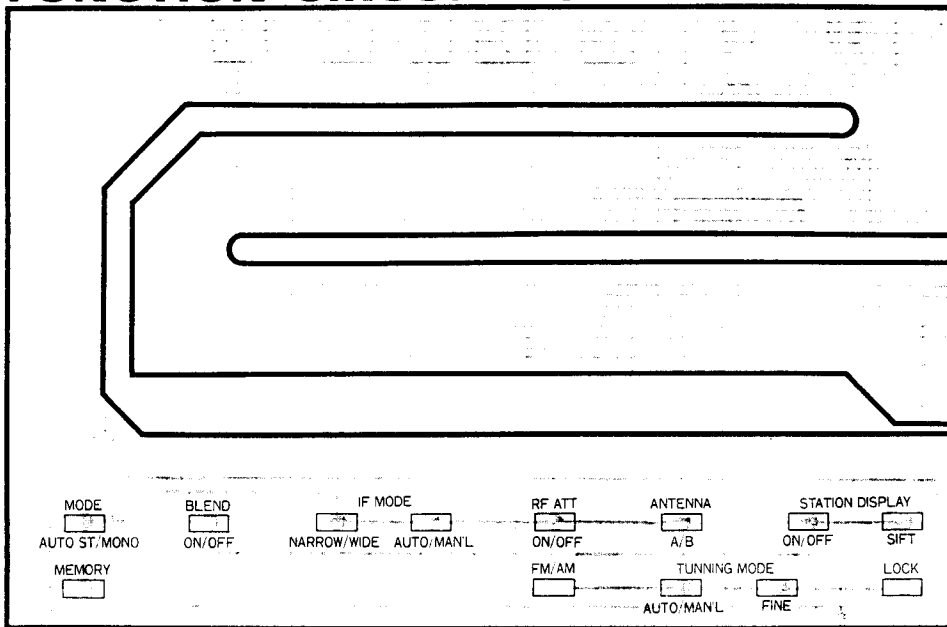

TO TUNER CIRCUIT BOARD (1)  
K4  
K3  
K2  
K1  
D4  
D3  
D2  
D1

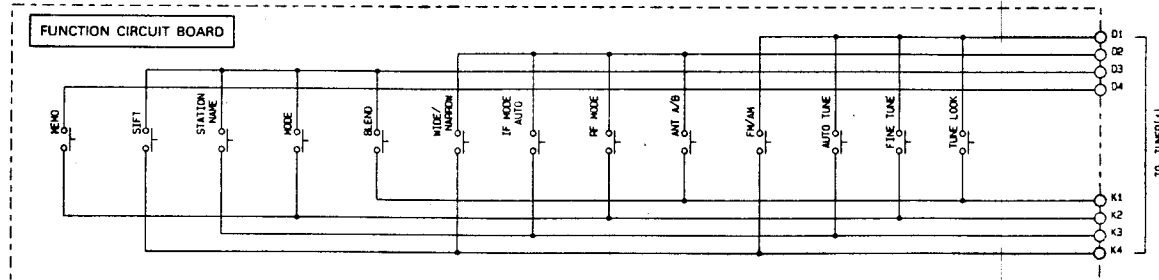
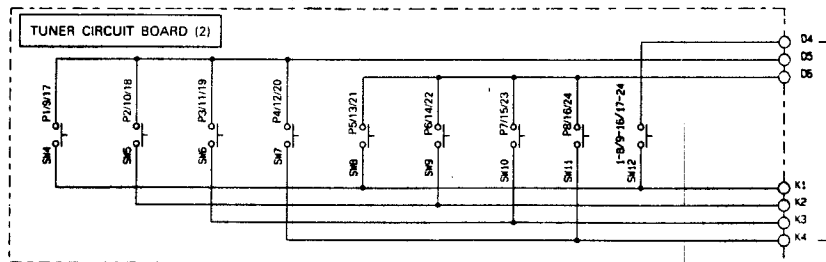
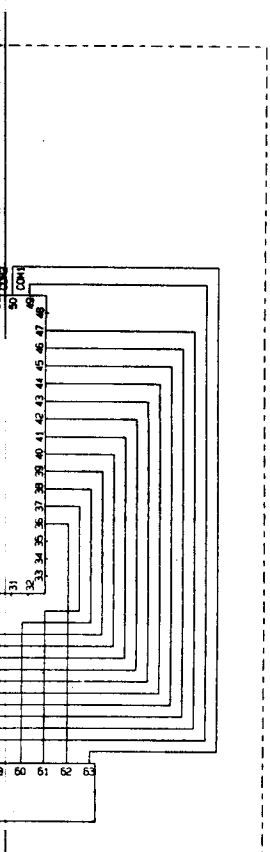

For Service Manuals Contact  
**MAURITRON TECHNICAL SERVICES**  
 8 Cherry Tree Rd, Chinnor  
 Oxon OX9 4QY  
 Tel: 01844-351694 Fax: 01844-352554  
 Email: enquiries@mauritron.co.uk

A

B

C

D

TX-1000/U/TX-2000

PRINTED CIRCUIT BOARD (Pattern Side)

1

2

3

4

5

6

7

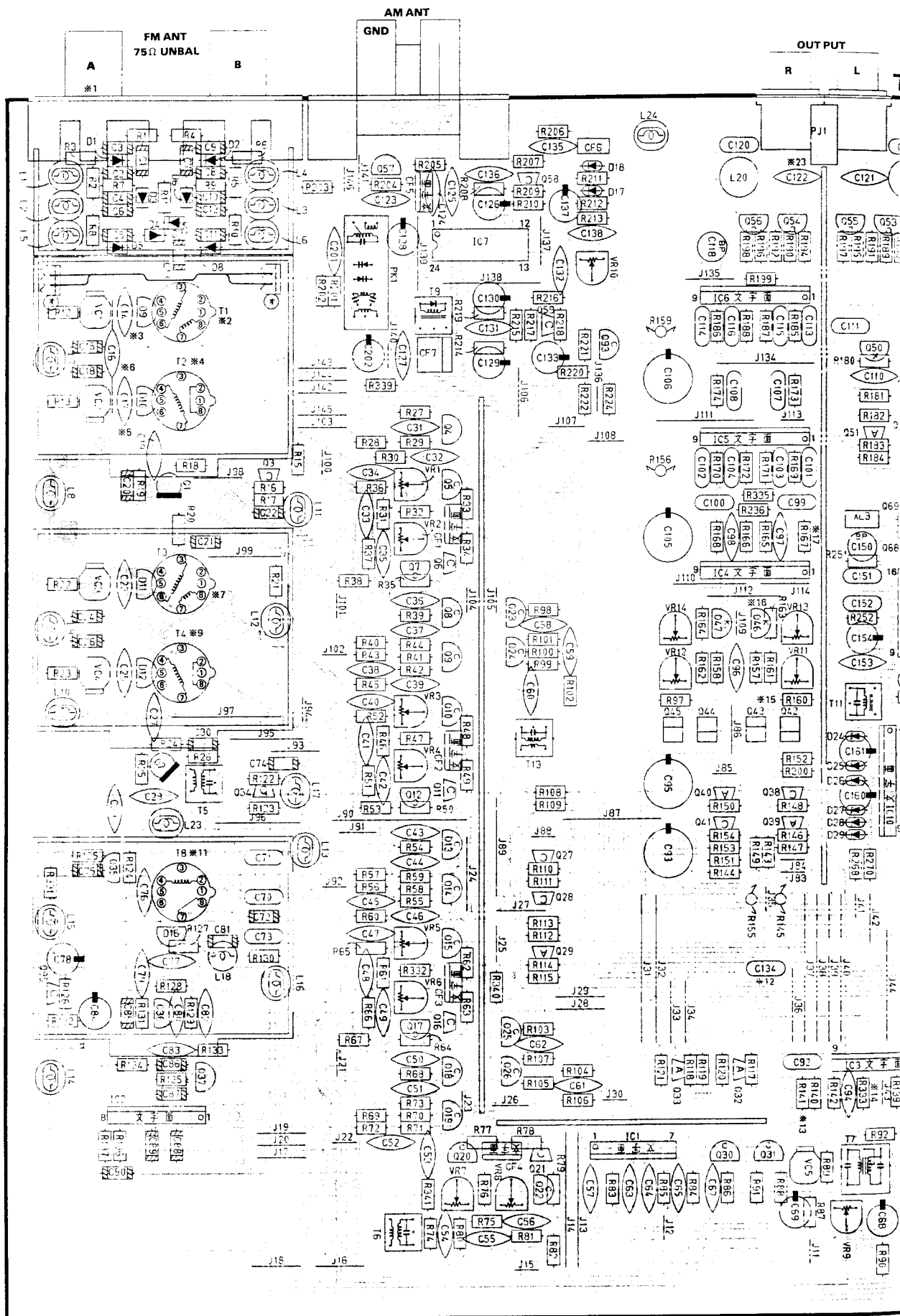

For Service Manuals Contact  
**MAURITRON TECHNICAL SERVICES**  
 8 Cherry Tree Rd, Chinnor  
 Oxon OX9 4QY  
 Tel: 01844-351694 Fax: 01844-352554  
 Email: enquiries@mauritron.co.uk

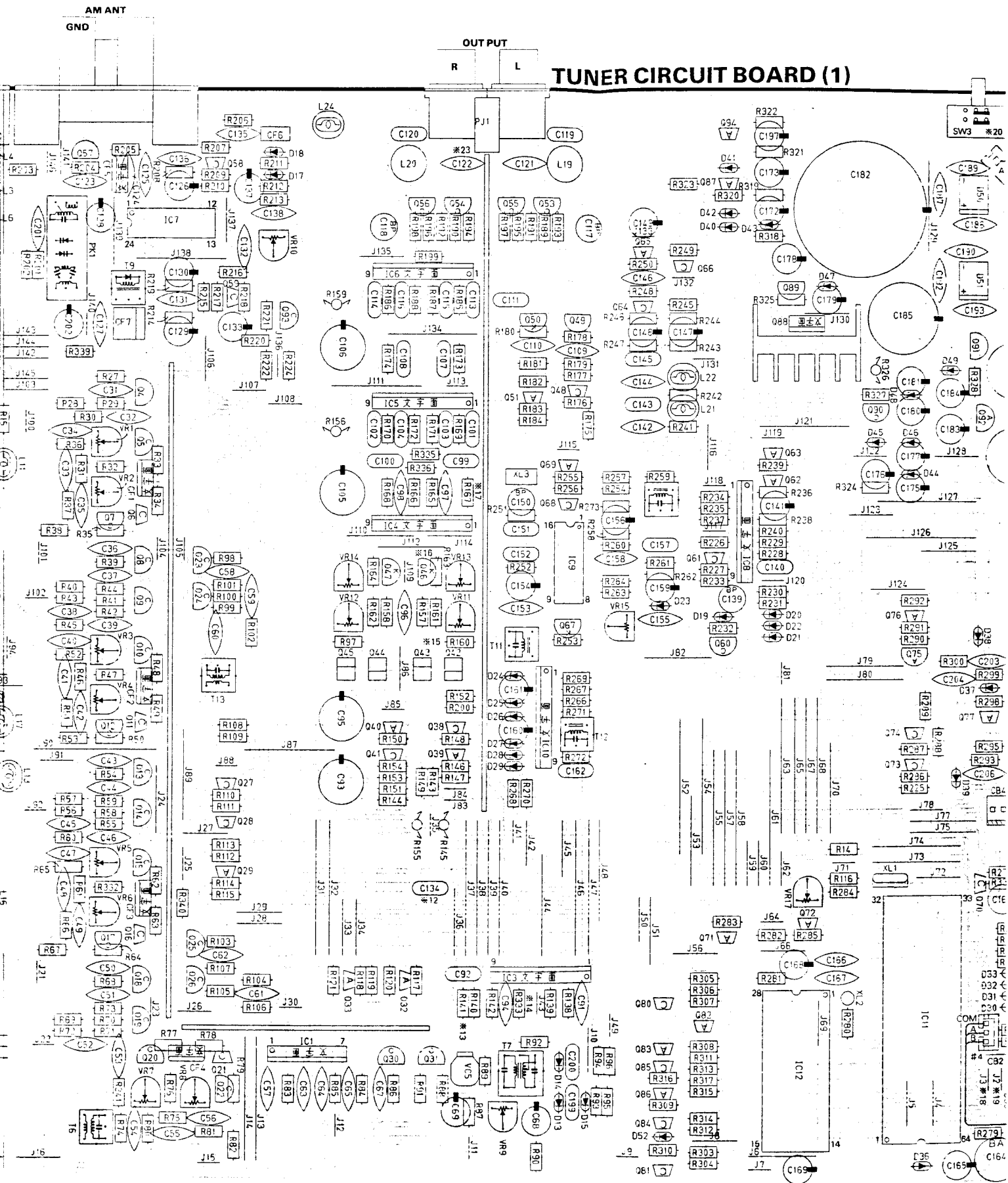

※ 文字面 : Component Side

# TUNER CIRCUIT BOARD (1)

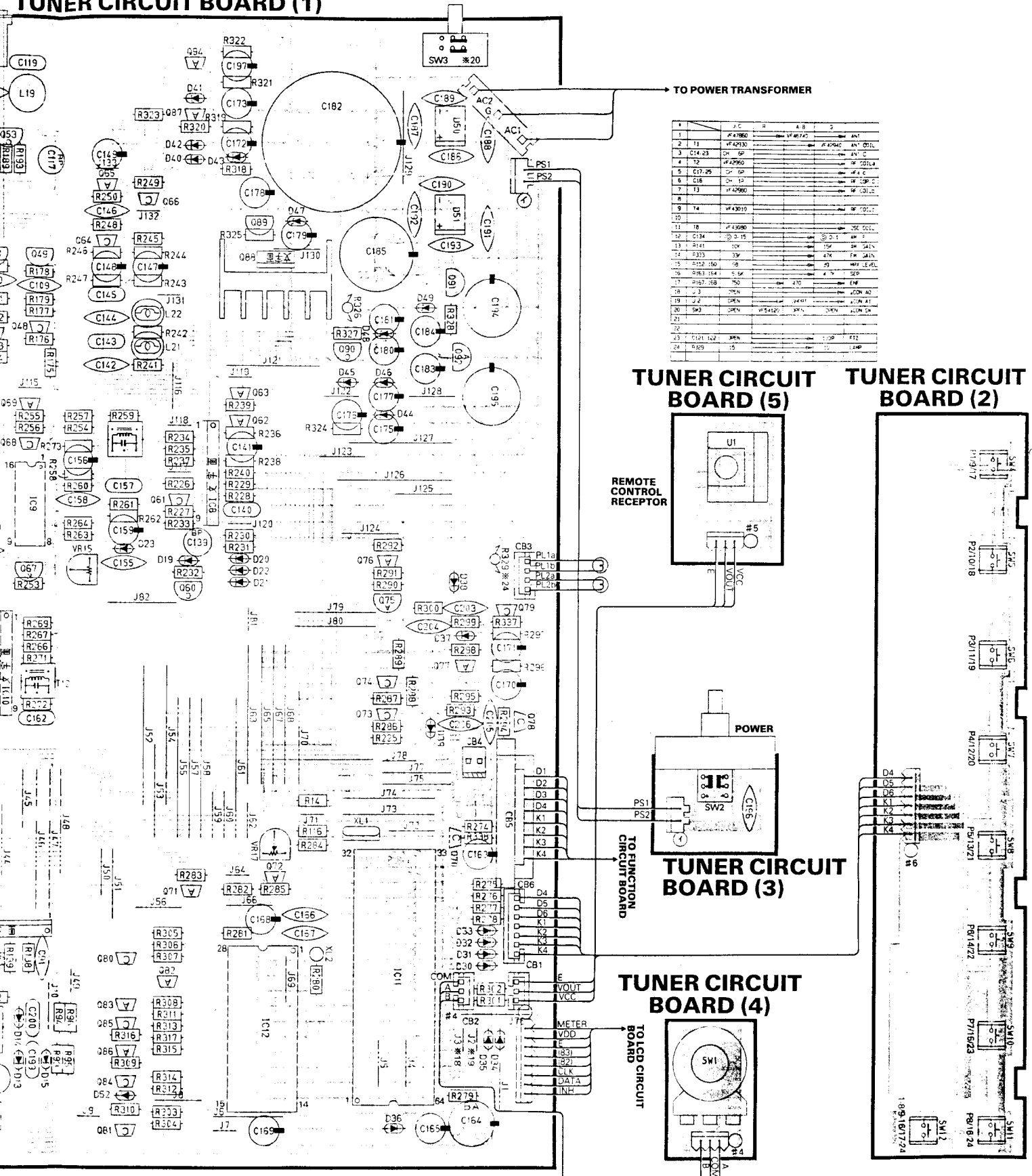

1	J.C	2	A.B	3	ANT
1	VF47860	VF46740			ANT
2	VF42130		VF42940		ANT OSC
3	VF42130	VF42940			ANT C
4	VF42950				RF TUNING
5	VF42950				RF C
6	VF42950				RF TUNING
7	VF42950				RF TUNING
8					
9	VF43010				RF TUNING
10					
11	VF43000				RF TUNING
12	VF43000				RF TUNING
13	VF43000				RF TUNING
14	VF43000				RF TUNING
15	VF43000				RF TUNING
16	VF43000				RF TUNING
17	VF43000				RF TUNING
18	VF43000				RF TUNING
19	VF43000				RF TUNING
20	VF43000				RF TUNING
21					
22					
23	VF43000				RF TUNING
24	VF43000				RF TUNING

## TUNER CIRCUIT BOARD (5)

## TUNER CIRCUIT BOARD (2)

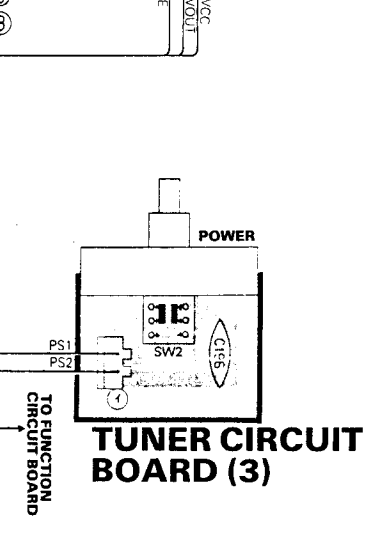
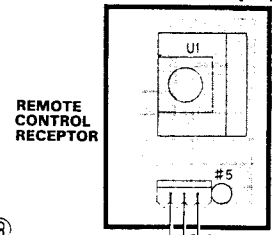

## TUNER CIRCUIT BOARD (4)

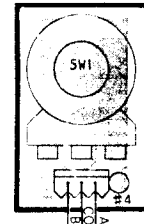

For Service Manuals Contact  
**MAURITRON TECHNICAL SERVICES**  
 8 Cherry Tree Rd, Chinnor  
 Oxon OX9 4QY  
 Tel: 01844-351604 Fax: 01844-352554  
 Email: [enquiries@mauratron.co.uk](mailto:enquiries@mauratron.co.uk)

# REMOTE CONTROL TRANSMITTER (RS-TX1000, RS-TX2000)

## SCHEMATIC DIAGRAM

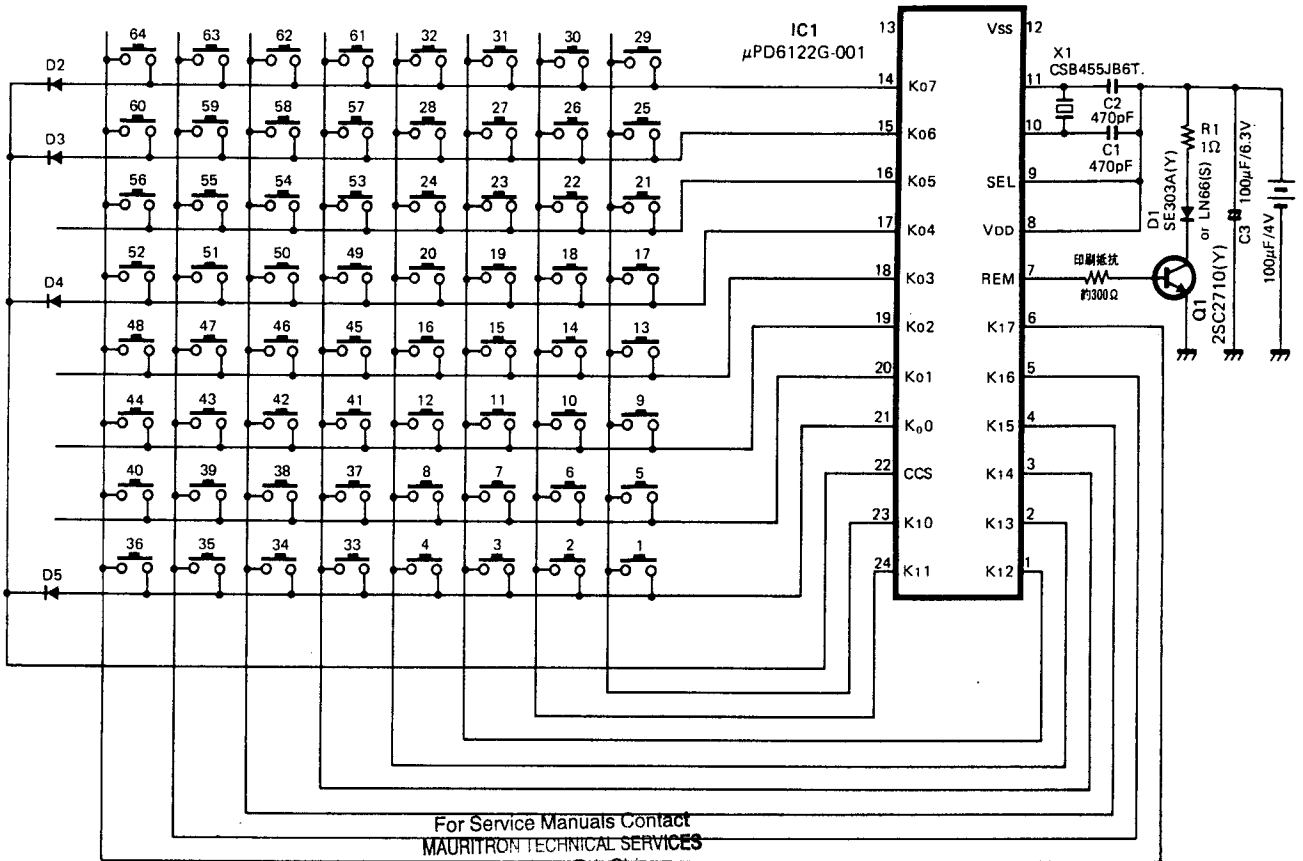

For Service Manuals Contact  
**MAURITRON TECHNICAL SERVICES**  
 8 Cherry Tree Rd, Chinnor  
 Oxon OX9 4QY  
 Tel:- 01844-351694 Fax:- 01844-352554  
 Email:- enquiries@mauritron.co.uk

## PRINTED CIRCUIT BOARD

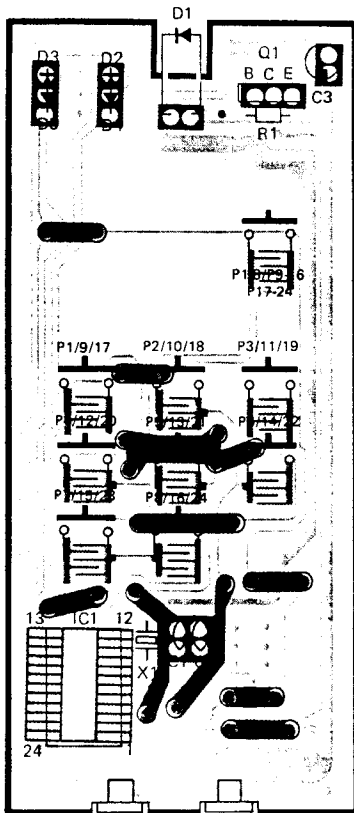

KEY NO.	DATA CODE	FUNCTION
1	00	
2	01	
3	02	
4	03	
5	04	
6	05	
7	06	
8	07	
9	08	
10	09	
11	0A	
12	0B	
13	0C	
14	0D	P1-8/9-16/17-24
15	0E	P1
16	0F	P2
17	10	P3
18	11	P4
19	12	P5
20	13	P6
21	14	P7
22	15	P8
23	16	
24	17	
25	18	
26	19	
27	1A	
28	1B	
29	1C	
30	1D	
31	1E	
32	1F	

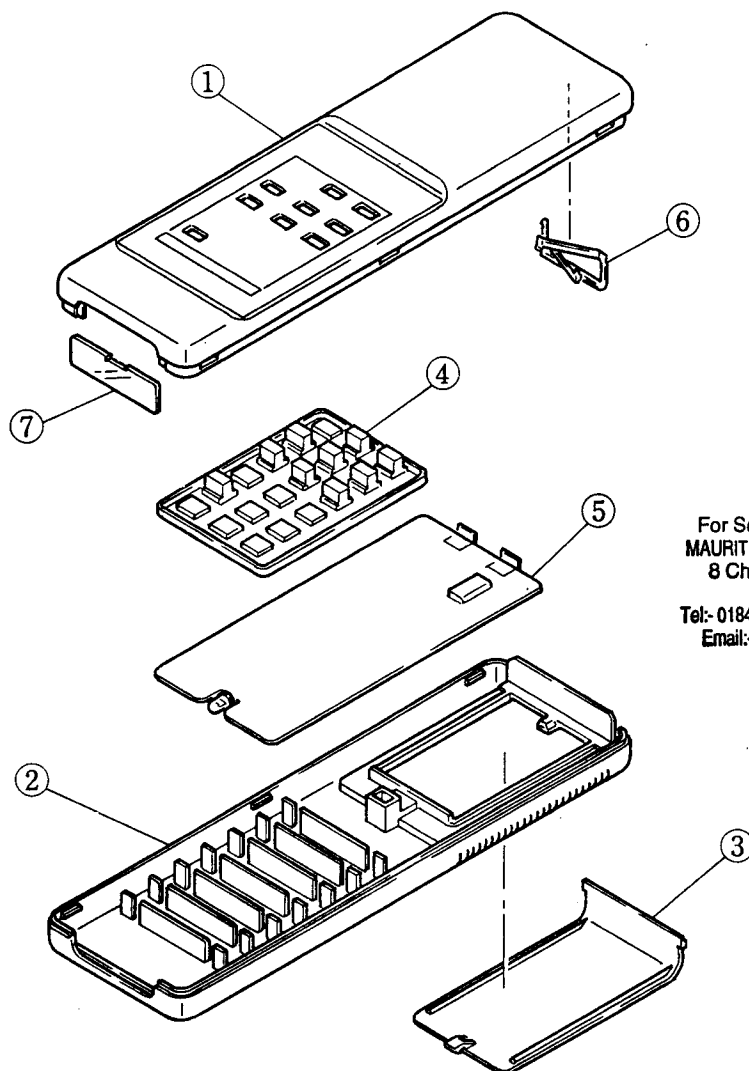

For Service Manuals Contact  
**MAURITRON TECHNICAL SERVICES**  
 8 Cherry Tree Rd, Chinnor  
 Oxon OX9 4QY  
 Tel:- 01844-351694 Fax:- 01844-352554  
 Email:- enquiries@mauritron.co.uk

Ref. No.	Part No.	Description	部品名	Remarks	Common Model	Markets	ランク
※	VF 43 20 00	Remote Control Transmitter	RS-TX2000	リモートコントロール トランスミッター		J	
※	VF 43 18 00	◇	RS-TX1000	◇		U,C,R,A,B,G	
※	1 CX 60 49 40	Case (A) Ass'y	RS-TX2000	ケース (A) Ass'y	UR64VCS671	J	
※	◇ CX 60 49 60	◇	RS-TX1000	◇	UR64VCS670	U,C,R,A,B,G	
2	CX 60 27 70	Case (B)		ケース (B)	UR64CS263B	RS-A2000	
3	CX 60 27 80	Lid, Battery		電池 蓋	UR64EC264B	RS-A2000	
※	4 CX 60 49 50	Rubber, Contact	RS-TX2000	ゴム 接点	UR64CT266Q		
※	◇ CX 60 49 70	◇	RS-TX1000	◇	UR64CT266P		
※	5 NX 60 27 60	P.C. Board Ass'y		プリント基板 Ass'y	UR64VPB573		
6	LX 60 02 80	Battery Terminal (A)		電池 電極板 (A)	UR52FD101	RS-KW5	
7	CX 60 05 10	Filter		スモーク板	UR52SB327		
※	NX 60 27 60	P.C. Board Ass'y		プリント基板 Ass'y			
※	iX 61 16 30	IC	μPD6122G001	IC1			
※	QX 60 01 50	Ceramic Resonator	CSB455JB6T	セラミック振動子	X1		
※	iX 61 24 00	Transistor	2SC2710 (Y)	トランジスター	Q1		
	iF 00 47 00	LED	SE303AY	赤外発光ダイオード	D1		
	FG 21 21 00	Ceramic Cap.	100pF 50V	セラコン	C1, 2		
	UJ 11 74 70	Electrolytic Cap.	47μF 6.3V	ケミコン	C3		
	iX 60 34 80	Diode	MA154WK	ダイオード	D2~5		
	LX 60 02 90	Battery Terminal (B)		電池 電極板 (B)			

※New Parts (新規部品)

# SCHEMATIC DIAGRAM

TUNER CIRCUIT BOARD (1)

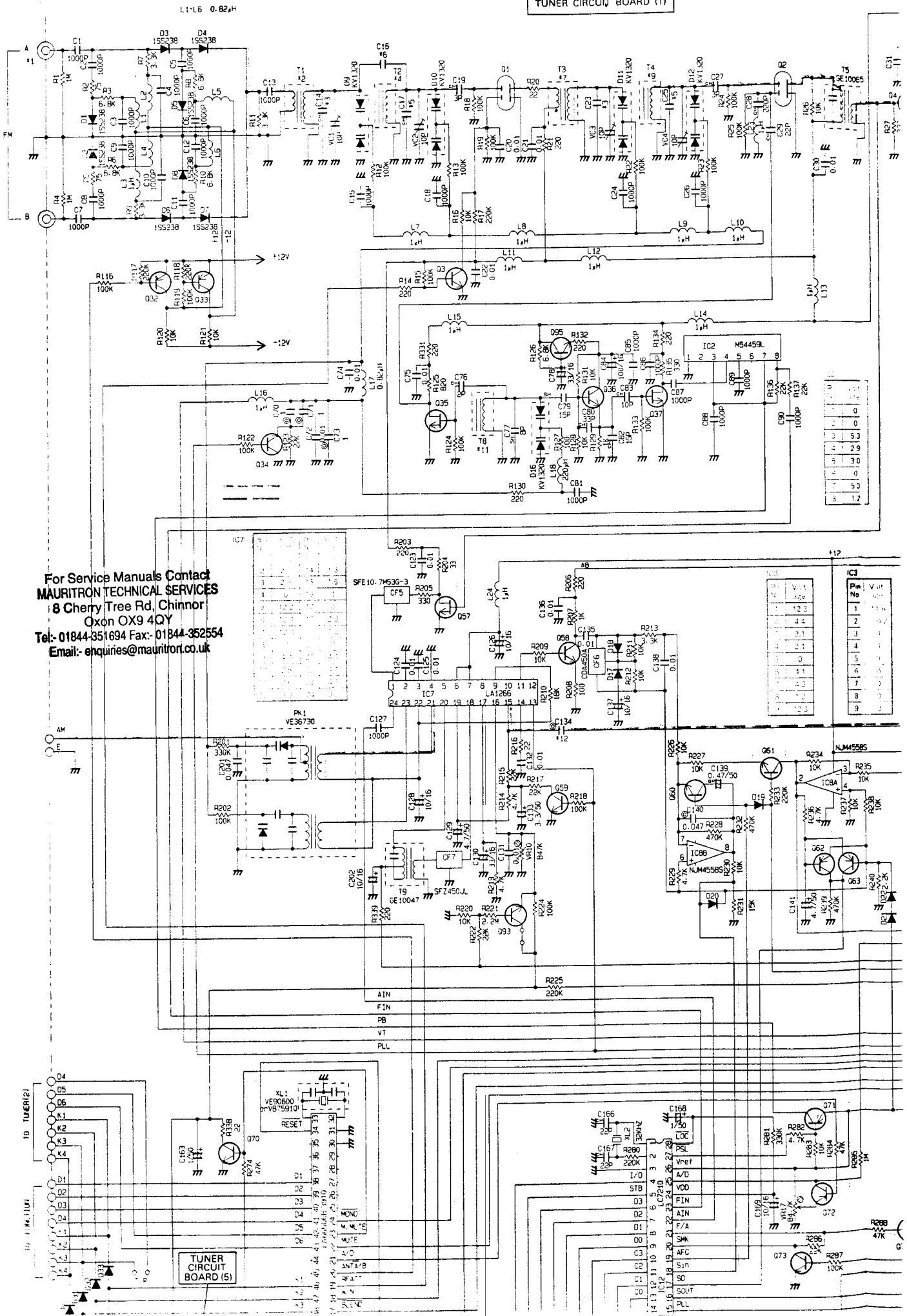

For Service Manuals Contact  
**MAURITRON TECHNICAL SERVICES**  
 8 Cherry Tree Rd, Chinnor  
 Oxon OX9 4QY  
 Tel:- 01844-351694 Fax:- 01844-352554  
 Email:- enquiries@mauritron.co.uk

TUNER CIRCUIT BOARD (5)



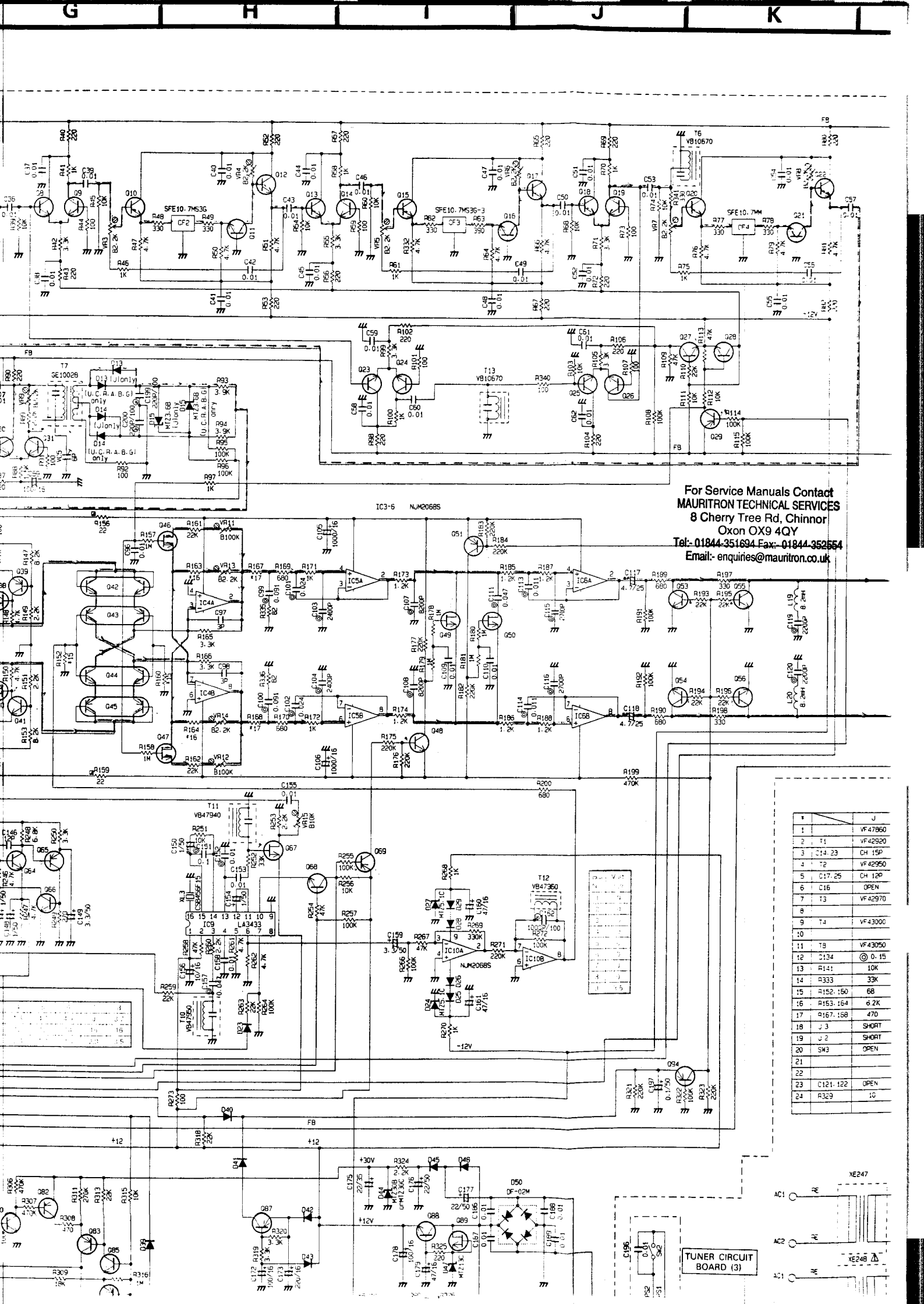

For Service Manuals Contact  
**MAURITRON TECHNICAL SERVICES**  
 8 Cherry Tree Rd, Chinnor  
 Oxon OX9 4QY  
 Tel: 01844-351694 Fax: 01844-352554  
 Email: enquiries@mauritron.co.uk

	J
1	VF47860
2	T1
3	C14, 23 CH 15P
4	T2
5	C17, 25 CH 12P
6	C16 OPEN
7	T3
8	
9	T4
10	
11	T8
12	C134 0.15
13	R141 10K
14	R333 33K
15	R152, 150 68
16	R153, 154 6.2K
17	R167, 168 470
18	J 3 SHORT
19	J 2 SHORT
20	SW3 OPEN
21	
22	
23	C121, 122 OPEN
24	R329 10

TUNER CIRCUIT BOARD (3)

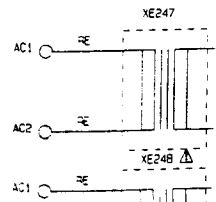

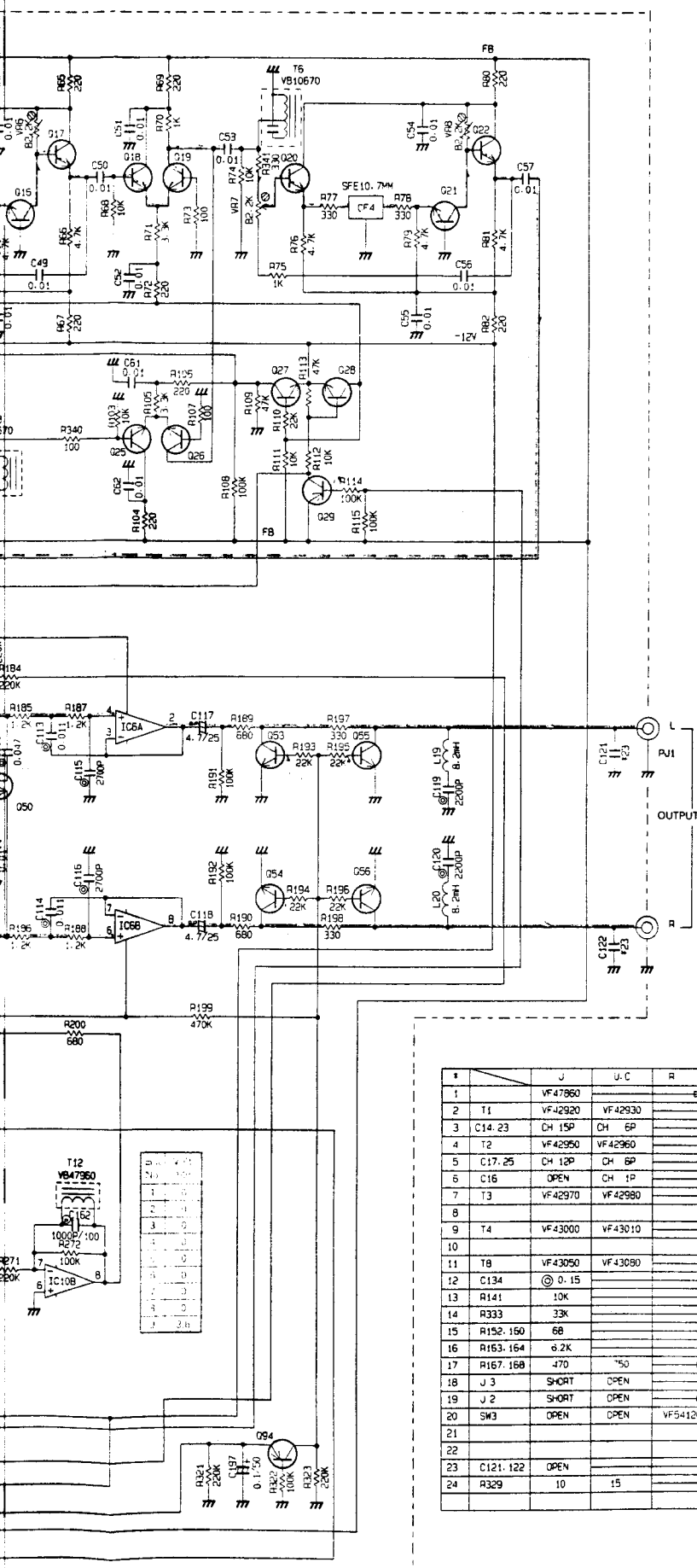

For Service Manuals Contact  
**MAURITRON TECHNICAL SERVICES**  
 8 Cherry Tree Rd, Shinnor  
 Oxon OX9 4QY  
 Tel:- 01844-351694 Fax:- 01844-352554  
 Email:- enquiries@mauritron.co.uk

#	J	U.C	R	A.B	G	
1	VF47860			VF46740		ANT
2	T1	VF42920	VF42930		VF42940	ANT COIL
3	C14.23	CH 15P	CH 6P			ANT C
4	T2	VF42950	VF42960			RF COILa
5	C17.25	CH 12P	CH 6P			RFa c
6	C16	OPEN	CH 1P			RF COP. C
7	T3	VF42970	VF42980			RF COILb
8						
9	T4	VF43000	VF43010			RF COILc
10						
11	T8	VF43050	VF43080			OSC COIL
12	C134	⊙ 0.15			⊙ 0.1	AM F
13	R141	10K			15K	AM GAIN
14	R333	33K			47K	FM GAIN
15	R152.150	68			39	MPX LEVEL
16	R163.164	6.2K			4.7K	SEP
17	R167.168	470	750	470		ENF
18	J 3	SHORT	OPEN			μCON AD
19	J 2	SHORT	OPEN	SHORT		μCON A1
20	SW3	OPEN	OPEN	VF54120	OPEN	μCON SW
21						
22						
23	C121.122	OPEN			100P	FTZ
24	R329	10	15		10	LAMP

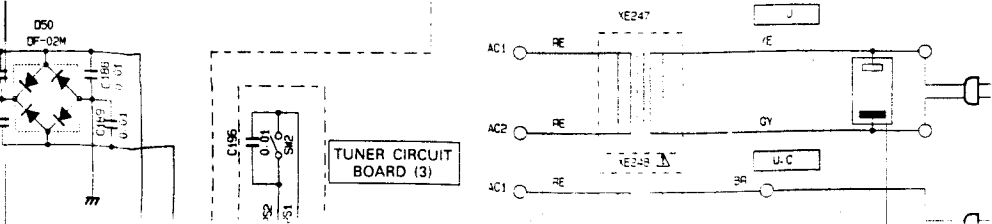

For Service Manuals Contact  
**MAURITRON TECHNICAL SERVICES**  
 8 Cherry Tree Rd, Chinnor  
 Oxon OX9 4QY  
 Tel: 01844-351694 Fax: 01844-352554  
 Email: enquiries@mauritron.co.uk

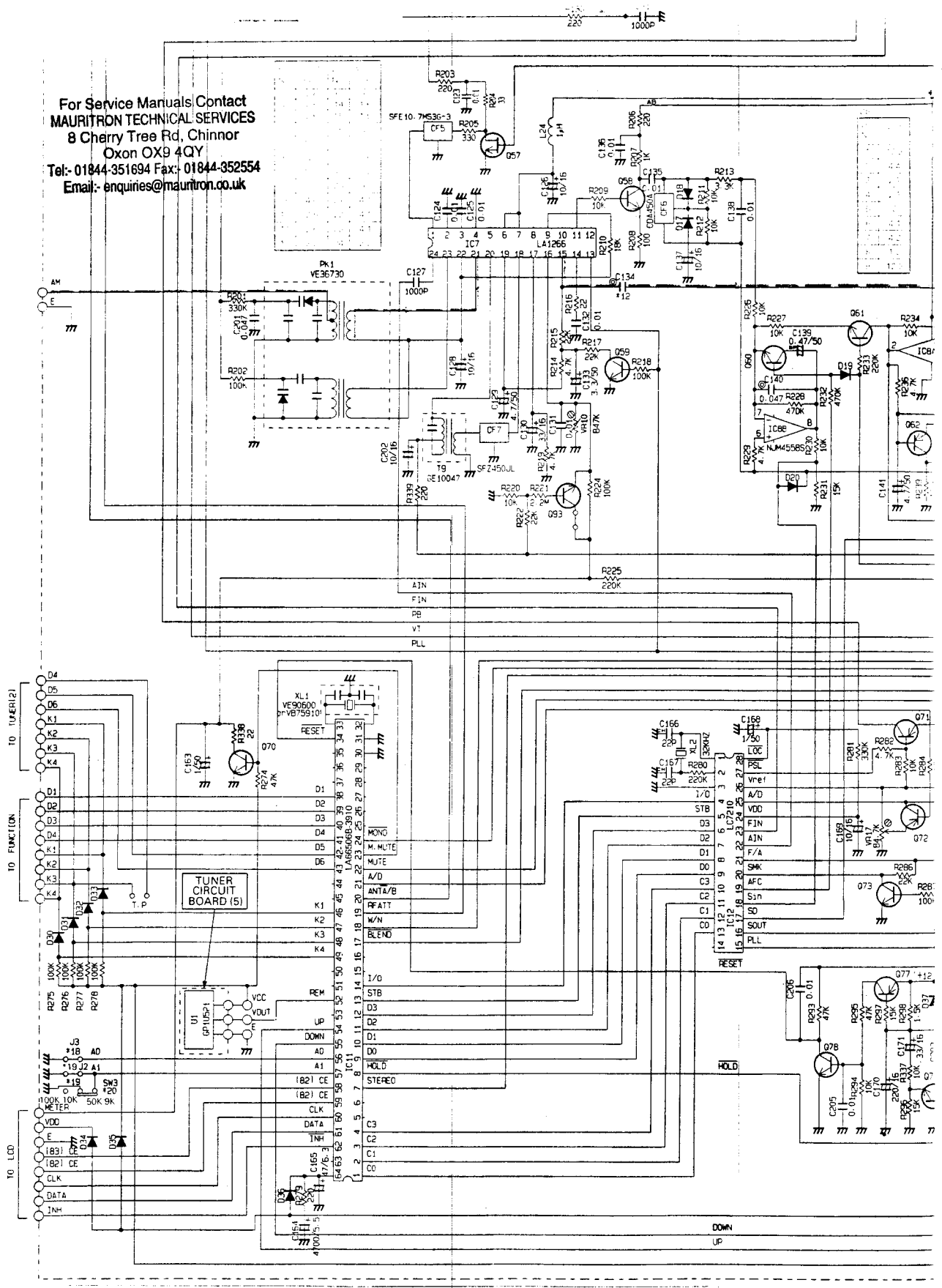

RESISTOR	REMARKS
(U).....	U.S.A model
(C).....	Canadian model
(A).....	Australian model
(G).....	European model
(B).....	British model
(R).....	General model

**NOTICE**  
 (U)..... U.S.A model  
 (C)..... Canadian model  
 (A)..... Australian model  
 (G)..... European model  
 (B)..... British model  
 (R)..... General model

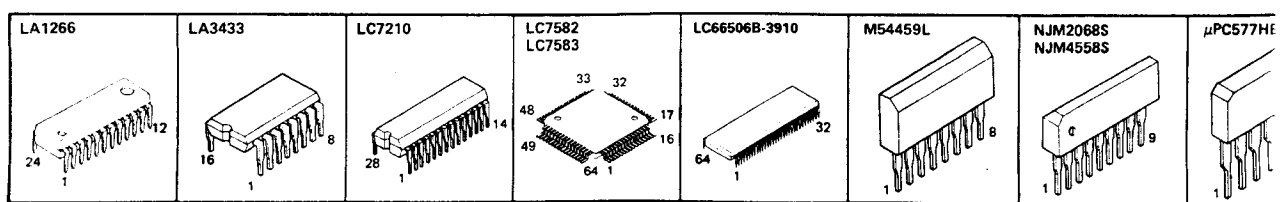

4  
5  
6  
7  
8  
9  
10

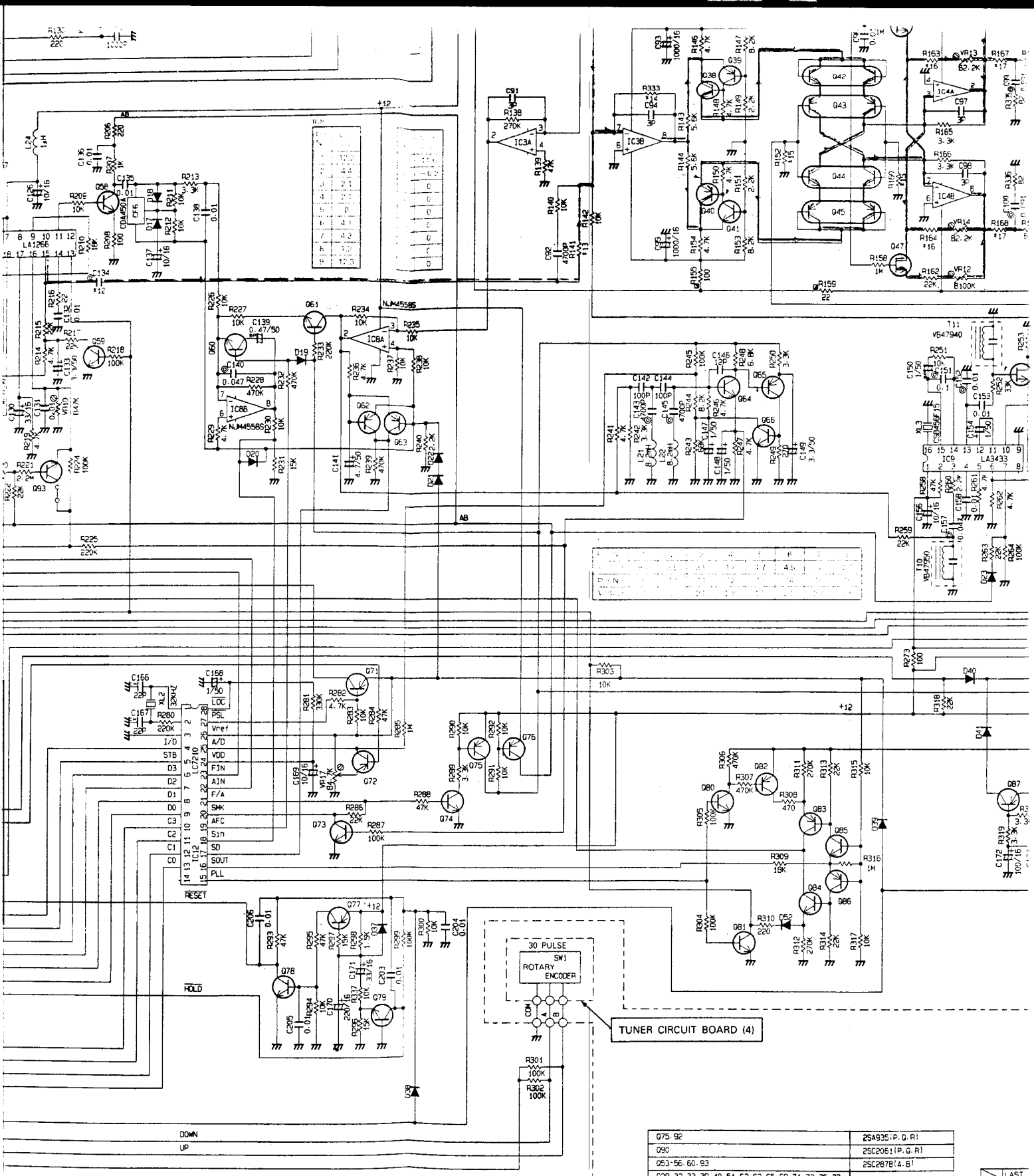

**NOTICE**  
 (U)..... U.S.A model  
 (C)..... Canadian model  
 (A)..... Australian model  
 (G)..... European model  
 (B)..... British model  
 (R)..... General model

REMARKS	PARTS NAME
NO MARK	CARBON FILM RESISTOR (1/6W)
☑	CARBON FILM RESISTOR
△	METAL OXIDE FILM RESISTOR
▲	METAL FILM RESISTOR
⊗	METAL PLATE RESISTOR
⊠	FIRE PROOF CARBON FILM RESISTOR
□	CEMENT MOLDED RESISTOR
⊙	SEMI VARIABLE RESISTOR
■	CHIP RESISTOR

075-92	25A935(P, G, R)
090	25C2061(P, G, R)
053-56, 60, 93	25C2878(A, B)
029-32, 33, 39, 40, 51-62, 63, 65-69, 71, 72, 76, 77	25A1317S
082, 63, 86, 87, 94	25C3330S
03, 6, 11, 16, 21, 27, 28, 34, 38, 41, 48, 58, 59, 61, 64	25C1809(M, N, P)
066, 68, 70, 73, 74, 78-81, 84, 85, 95	25C2995(A, D, Y)
05, 7-10, 12-15, 17-20, 22-26, 30, 31	25C1847
036	25K105(H)
068	25K241(Y)
049, 89, 91	25K101(Y, GR)
04, 35, 37, 57	25A123E
01-2	25C3065
043, 45	25K105(F, H)
042, 44	
046, 47, 50, 67	

	LAST
C	206
R	341
G	95
D	52

<b>C66506B-3910</b> 	<b>M54459L</b> 	<b>NJM2068S</b> <b>NJM4558S</b> 	<b>μPC577HEF</b> 	<b>2SA935P, Q, R</b> <b>25C2061P, Q, R</b> 	<b>2SA1317S</b> <b>25C1809M, N, P</b> <b>25C3330S</b> <b>25K105 F, H</b> <b>25K105 H</b> <b>25K241Y</b> 	<b>25C1847</b> 	<b>25C2878AB</b> 	<b>25C2995 R, OY</b> 
-------------------------	--------------------	--	----------------------	---	--	--------------------	----------------------	--------------------------

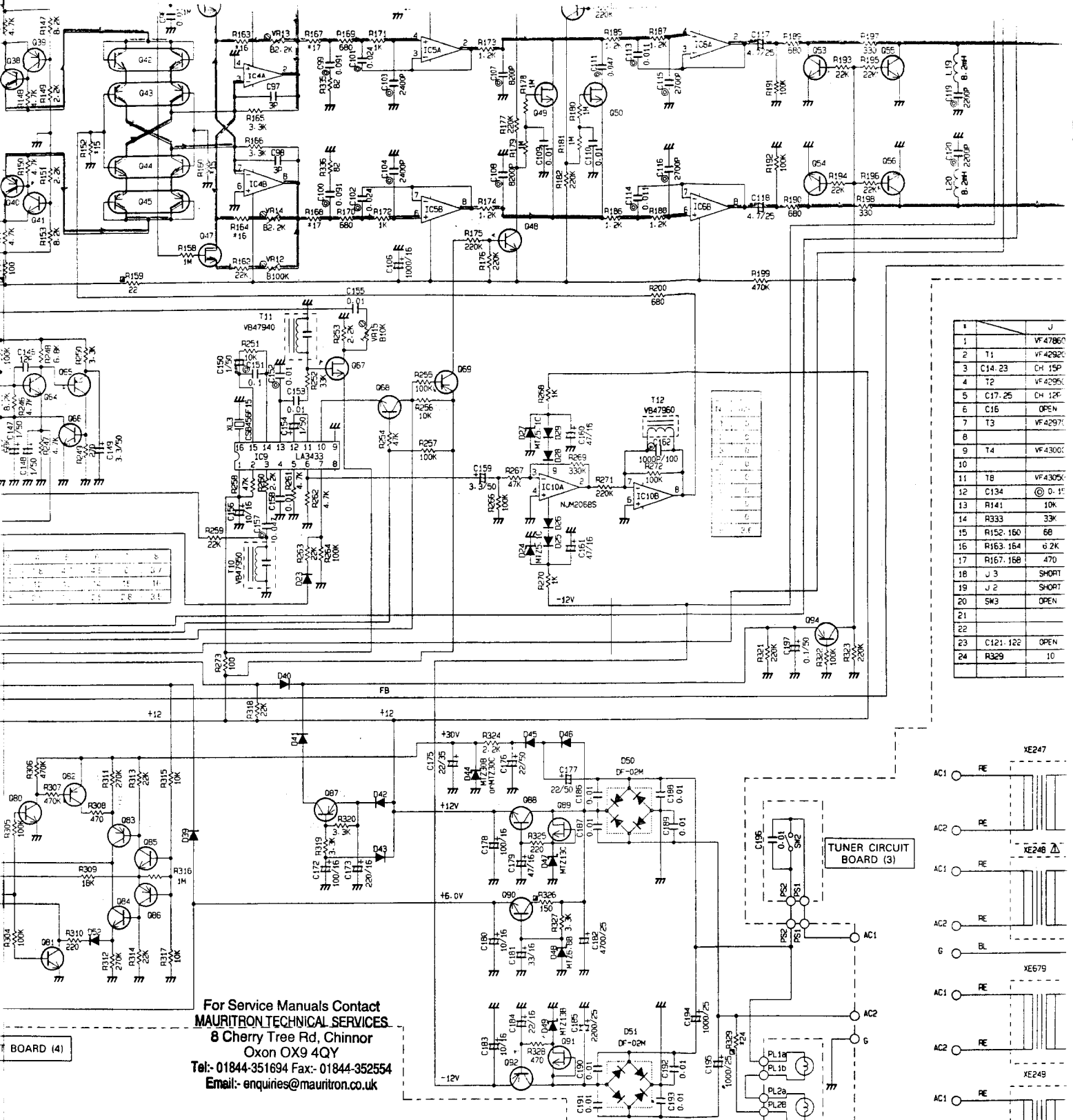

1	J
1	VF47960
2	T1
3	C14, 23 CH 15P
4	T2
5	VF4295K
6	C16 CH 12P
7	T3
8	VF4297K
9	T4
10	VF4300K
11	T8
12	C134 CH 0.15P
13	R141 10K
14	R333 33K
15	R152, 160 68
16	R163, 164 6.2K
17	R167, 168 470
18	J 3
19	J 2
20	SW3
21	
22	
23	C121, 122 OPEN
24	R329 10

For Service Manuals Contact  
**MAURITRON TECHNICAL SERVICES**  
 8 Cherry Tree Rd, Chinnor  
 Oxon OX9 4QY  
 Tel: 01844-351694 Fax: 01844-352554  
 Email: enquiries@mauritron.co.uk

BOARD (4)

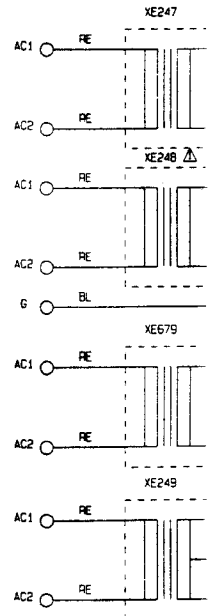

25A935(P, D, R)
25C2061(P, G, R)
25C2678(A, B)
25A13175
25C33305
25C1809(M, N, P)
25C2995(R, O, Y)
25C1847
25K105(H)
25K241(Y)
35K1011(Y, GR)
25A1238
25C3065
25K105(F, H)

LAST NO.	UN LISTED NO.
C 206	112
R 341	
G 95	52
D 52	

REMARKS	PARTS NAME	QTY
NO MARK	ELECTROLYTIC CAPACITOR	11
NO MARK	CERAMIC CAPACITOR	
⊙	POLYESTER FILM CAPACITOR	
○	POLYSTYRENE FILM CAPACITOR	
⊖	MICA CAPACITOR	
⊕	POLYPROPYLENE FILM CAPACITOR	
⊗	SEMICONDUCTIVE CERAMIC CAPACITOR	

UNLESS OTHERWISE SPECIFIED
PNP TRANSISTOR
NPN TRANSISTOR
DIODE
1SS287

25C1847

25C2878AB

25C2995 R, OY

25A1238  
25C3065

35K101 Y, GR

DF-02M

KV1320

MTZ3.6B MTZ13B  
 MTZ5.1C MTZ13C  
 MTZ6.8B MTZ30B  
 MTZ30C

1SS238  
1SS287

All vol  
 Comp  
 must l  
 origina  
 Schem



■ WARNING

# PARTS LIST

Components having special characteristics are marked  $\Delta$  and must be replaced with parts having specifications equal to those originally installed.

• Carbon resistors 1/4 W are not included in the ELECTRICAL PARTS list. For the parts No. of the carbon resistor, refer to P.32 .

## ELECTRICAL PARTS

Ref. No.	Part No.	Description	部 品 名	Remarks	Common Model	Markets	ランク
※	NA 09 90 40	Tuner Circuit Board	チューナーシート			J	
※	NA 09 90 50	〃	〃			U, C	
※	NA 09 90 60	〃	〃			R	
※	NA 09 90 70	〃	〃	TX-1000		A, B	
※	NA 09 90 80	〃	〃			W/G	
	Fi 19 01 00	Ceramic Cap.	セラコン	C16		U,C,R,A,B,W/G	
	VA 75 99 00	〃	〃	C76			
	Fi 19 03 00	〃	〃	C19, 27			
	Fi 19 11 00	〃	〃	C83			
	VA 76 03 00	〃	〃	C17, 25		U,C,R,A,B,W/G	
※	VA 76 07 00	〃	〃	〃		J	
	VA 76 03 00	〃	〃	C14, 23		U,C,R,A,B,W/G	
※	VA 76 08 00	〃	〃	〃		J	
※	VA 76 08 00	〃	〃	C82			
	VA 76 10 00	〃	〃	C29, 166, 167			
	Fi 19 13 30	〃	〃	C80			
	Fi 19 22 20	〃	〃	C28			
	FG 21 08 00	〃	〃	C77			
	FG 21 11 50	〃	〃	C79			
	FG 20 03 00	〃	〃	C91, 94, 97, 98			
	FG 21 11 20	〃	〃	C146			
	FG 21 21 00	〃	〃	C142,144			
	FG 21 21 00	〃	〃	C121,122		W/G	
	FG 21 31 00	〃	〃	C127			
	FG 24 41 00	〃	〃	C31~65,67,96,109,110,123~125,131,132,135,136,138,153,155,158,186~193,196,203~207			
	FG 24 44 70	〃	〃	C201			
	Fi 44 31 00	〃	円筒形セラコン	C1~13,15,18,24,26,81,85~90			
	VF 46 73 00	〃	〃	C20~22,30,72,74,75			
	FA 15 32 20	Mylar Cap.	マイラーコン	C119, 120			
	FA 15 32 40	〃	〃	C103, 104			
	FA 15 32 70	〃	〃	C115, 116			
	FA 15 34 70	〃	〃	C92, 143, 145			
	FA 15 38 20	〃	〃	C107, 108			
	FA 15 41 00	〃	〃	C152			
	FA 15 41 10	〃	〃	C113, 114			
	FA 15 42 40	〃	〃	C101, 102			
	FA 15 44 70	〃	〃	C111, 140, 157			
	FA 15 49 10	〃	〃	C99, 100			
	FA 15 51 00	〃	〃	C151			
	FA 15 51 00	〃	〃	C134		W/G	
	FA 15 51 50	〃	〃	〃		J,U,C,R,A,B	
	FA 15 61 00	〃	〃	C70, 71, 73			
	UJ 11 74 70	Electrolytic Cap.	ケミコン	C165			
	UH 13 71 00	〃	〃	C126, 128, 137, 156, 169, 180, 183, 202			
	UH 13 72 20	〃	〃	C184			
	UJ 13 73 30	〃	〃	C78, 130, 171, 181			
	UJ 13 74 70	〃	〃	C160, 161, 179			
	UJ 13 81 00	〃	〃	C68, 69, 84, 172, 178			
	UJ 13 82 20	〃	〃	C170, 173			
	UH 05 72 20	〃	〃	C175			

※New Parts (新規部品)

(NOTE) W/G ..... TX-1000 Markets: G  
TX-2000 Markets: W

For Service Manuals Contact  
MAURITRON TECHNICAL SERVICES  
8 Cherry Tree Rd, Chinnor  
Oxon OX9 4QY  
Tel:- 01844-351694 Fax:- 01844-352554  
Email:- enquiries@mauritron.co.uk

Ref. No.	Part No.	Description	部 品 名	Remarks	Common Model	Markets	ランク
	UH 16 61 00	Electrolytic Cap.	1 $\mu$ F 50V	ケ ミ コ ン	C147, 148, 154, 163, 168		
	UH 16 63 30	〃	3.3 $\mu$ F 50V	〃	C133, 149, 159		
	UH 16 64 70	〃	4.7 $\mu$ F 50V	〃	C129, 141		
	UJ 16 72 20	〃	22 $\mu$ F 50V	〃	C176, 177		
	UH 13 91 00	〃	1000 $\mu$ F 16V	〃	C93, 95, 105, 106		
	UH 14 91 00	〃	1000 $\mu$ F 25V	〃	C194, 195		
	UJ 14 92 20	〃	2200 $\mu$ F 25V	〃	C185		
	VB 09 95 00	〃	4700 $\mu$ F 25V	ブ ロ ッ ク ケ ミ コ ン	C182		
	VB 17 01 00	〃	4700 $\mu$ F 5.5V	ケ ミ コ ン	C164		
	UK 34 64 70	〃	4.7 $\mu$ F 25V	B P コ ン	C117, 118		
	UK 66 54 70	〃	0.47 $\mu$ F 50V	〃	C139		
	FM 11 61 00	〃	1 $\mu$ F 50V	〃	C150		
	UT 45 22 20	Polypropylene Film Cap.	220pF 100V	ポ リ プ ロ コ ン	C199, 200		
	UT 45 31 00	〃	1000pF 100V	〃	C162		
※	VF 43 11 00	Trimmer Capacitor	6pF VCT51A13A	ト リ マ ー コ ン	VC5		
※	VF 43 13 00	〃	10pF VCT51C712A	〃	VC1~4		
	GE 10 02 80	FM Discriminator Coil		FM ディスクリコイル	T7		
	GE 10 04 70	AM IFT Coil		AM IFT コイル	T9		
	GE 10 06 50	FM IFT Coil		FM IFT コイル	T5		
	VB 10 67 00	FM IFT Coil	10.7MHz	FM IFT コイル	T6, 13		
	VB 47 94 00	LC Filter	19Hz FB-7SG	LC フィルター	T11		
	VB 47 95 00	〃	20kHz FB-7SG	〃	T10		
	VB 47 96 00	〃	38kHz FB-7SG	〃	T12		
※	VF 42 92 00	FM ANT Coil		FM ANT コイル	T1	J	
※	VF 42 93 00	〃		〃	〃	U,C,R,B	
※	VF 42 94 00	〃		〃	〃	W/G	
※	VF 42 95 00	FM RF Coil a		FM RF コイル a	T2	J	
※	VF 42 96 00	〃		〃	〃	U,C,R,B,W/G	
※	VF 42 97 00	FM RF Coil b		FM RF コイル b	T3	J	
※	VF 42 98 00	〃		〃	〃	U,C,R,B,W/G	
※	VF 43 00 00	FM RF Coil c		FM RF コイル c	T4	J	
※	VF 43 01 00	〃		〃	〃	U,C,R,B,W/G	
※	VF 43 05 00	FM OSC Coil		FM OSC コイル	T8	J	
※	VF 43 08 00	〃		〃	〃	U,C,R,B,W/G	
	GE 90 06 90	Coil	8.2mH L-8	コ イ ル	L19, 20		
	VB 05 69 00	〃	220 $\mu$ H ELF0505	〃	L18		
	VB 10 03 00	〃	8.2mH EL0607	〃	L21, 22		
	VB 17 03 00	〃	1 $\mu$ H EL0606	〃	L7~16, 23, 24		
※	VF 96 39 00	〃	0.82 $\mu$ H EL0405	〃	L1~6, 17		
	GG 00 04 20	AM Ceramic Discriminator	CDA450A	AM セラミック式ディスクリ	CF6		
	VC 21 90 00	AM Ceramic Filter	SFZ450JL	AM セラミックフィルター	CF7		
※	VF 46 58 00	FM Ceramic Filter	SFE10.7MM	FM セラミックフィルターキット	CF1, 4		
		〃	SFE10.7MS3G-3	〃	CF2, 3, 5		
	QU 00 39 00	Quartz Crystal Unit	32kHz	水 晶 振 動 子	XL2		
※	VE 90 59 00	Ceramic Resonator	CSB456F15	セラミック振動子	XL3		
	VB 75 91 00	〃	4MHz EFO-FC4004A4	〃	XL1		
	HV 45 41 00	Flame Ploof Carbon Resistor	10 $\Omega$ 1/4W	不 燃 化 カ ー ボ ン 抵 抗	R329	J, W	

※New Parts (新規部品)

For Service Manuals Contact  
MAURITRON TECHNICAL SERVICES  
8 Cherry Tree Rd, Chinnor  
Oxon OX9 4QY  
Tel: 01844-351694 Fax: 01844-352554  
Email: enquiries@mauritron.co.uk

Ref. No.	Part No.	Description	部品名	Remarks	Common Model	Markets
KA 90 83 80	Tact Switch	EVO-ORB-04M	タクトスイッチ	SW4-12		
VE 32 73 00		KHH-MA901			Inter-changeable	
VF 54 13 00	Push Switch	SPU112	プッシュスイッチ	SW2		
VF 54 12 00	Slide Switch	SSS111	スライドスイッチ	SW3 Frequency Step		R
VG 20 04 00	Rotary Encoder	EC16B30B	ロータリーエンコーダー	SW1		
VE 62 29 00	Remote Control Receiver	GPU521	リモコン受光ユニット	U1		
VF 43 16 00	Pin Jack	2P	ピンジャック	PJ1		
VE 36 73 00	AM Coil Pack		AM電子調音コイルパック			
LB 20 13 00	Base Pin		ベースピン	CB4		
VD 00 46 00			I型 PH ベースピン	CB1,2		
VD 00 47 00				CB3		
VD 00 50 00				CB6		
VF 46 59 00	Connector		FPC コネクター	CB5		
LA 00 23 20	Lapping Terminal	i=type 3P P=7.5	ラッピング端子板			
VE 36 56 00	Push Terminal		プッシュターミナル			J.U.C.R
VF 47 86 00	Socket, F		ソケット			A.B.WG
VF 46 74 00	Plug		プラグ			
VB 71 57 00	PH Connector Assy	B&C 7P L=250	PHコネクター Assy			
VB 70 92 00		B&C 3P L=400				
VB 71 74 00		B&C 8P L=250				
VB 69 12 00		B&B 2P L=70				
VG 26 65 00	Heat Sink		放熱器			
BB 07 04 10	Bus Bar	L=55	バスバー			
BB 07 04 30		L=145				
VF 20 83 00	Shield Case A		シールドケース A			
VF 20 84 00			シールドケース B			
ED 33 00 66	Bind Head Screw	3 x 6 FCM3-BL	バインドヘッドネジ			
MA 09 90 90	LCD Circuit Board		LCD 表示シート	TX-2000		
MA 09 91 00				TX-1000/U		
FG 21 26 80	Ceramic Cap.	680pF	セラミックコンデンサ	C501		
FG 21 31 00		1000pF		C502		
UH 13 71 00	Electrolytic Cap.	10μF 16V	電解コンデンサ	C503		
XB 41 70 01	IC	LC7582	IC	IC501		
XB 76 40 01		LC7583		IC502		
VB 85 87 00	Base Pin	L=type	PH ベースピン	CB501		
VE 85 36 00	Display		LCD 表示器	TX-2000		
VF 86 48 00				TX-1000/U		

\*New Parts (新部品)

Ref. No.	Part No.	Description	部品名	Remarks	Common Model	Markets
HV 45 41 50	14W	Flame Proof Carbon Resistor	不燃化カーボン抵抗	R329		UCRA,B
HV 45 42 20	14W			R156, 159		
HV 45 51 00	14W			R145, 155		
HV 45 51 50	14W			R326		
VA 78 77 00		Semi Variable Resistor	半可変抵抗	VR1~9, 13, 14	Inter-changeable	
VB 14 08 00						
VA 78 79 00				VR17		
VA 78 80 00				VR15	Inter-changeable	
HT 79 00 20						
VA 78 83 00				VR10	Inter-changeable	
VB 24 42 00						
VA 78 84 00				VR11, 12		
IA 09 35 10	P.O.R	Transistor	トランジスタ	Q75, 92		
IC 20 61 10	P.O.R			Q30		
IC 28 78 20	A.B			Q33~56, 60, 93		
VC 21 87 00				Q38, 39, 38, 40, 51, 52, 53, 54, 55, 56, 57, 58, 59, 60, 61, 62, 63, 64, 65, 66, 67, 68, 69, 70, 71, 72, 73, 74, 75, 76, 77, 78, 79, 80, 81, 82, 83, 84, 85, 86, 87, 88, 89, 90, 91, 92, 93, 94, 95, 96, 97, 98, 99, 100, 101, 102, 103, 104, 105, 106, 107, 108, 109, 110, 111, 112, 113, 114, 115, 116, 117, 118, 119, 120, 121, 122, 123, 124, 125, 126, 127, 128, 129, 130, 131, 132, 133, 134, 135, 136, 137, 138, 139, 140, 141, 142, 143, 144, 145, 146, 147, 148, 149, 150, 151, 152, 153, 154, 155, 156, 157, 158, 159, 160, 161, 162, 163, 164, 165, 166, 167, 168, 169, 170, 171, 172, 173, 174, 175, 176, 177, 178, 179, 180, 181, 182, 183, 184, 185, 186, 187, 188, 189, 190, 191, 192, 193, 194, 195, 196, 197, 198, 199, 200, 201, 202, 203, 204, 205, 206, 207, 208, 209, 210, 211, 212, 213, 214, 215, 216, 217, 218, 219, 220, 221, 222, 223, 224, 225, 226, 227, 228, 229, 230, 231, 232, 233, 234, 235, 236, 237, 238, 239, 240, 241, 242, 243, 244, 245, 246, 247, 248, 249, 250, 251, 252, 253, 254, 255, 256, 257, 258, 259, 260, 261, 262, 263, 264, 265, 266, 267, 268, 269, 270, 271, 272, 273, 274, 275, 276, 277, 278, 279, 280, 281, 282, 283, 284, 285, 286, 287, 288, 289, 290, 291, 292, 293, 294, 295, 296, 297, 298, 299, 300, 301, 302, 303, 304, 305, 306, 307, 308, 309, 310, 311, 312, 313, 314, 315, 316, 317, 318, 319, 320, 321, 322, 323, 324, 325, 326, 327, 328, 329, 330, 331, 332, 333, 334, 335, 336, 337, 338, 339, 340, 341, 342, 343, 344, 345, 346, 347, 348, 349, 350, 351, 352, 353, 354, 355, 356, 357, 358, 359, 360, 361, 362, 363, 364, 365, 366, 367, 368, 369, 370, 371, 372, 373, 374, 375, 376, 377, 378, 379, 380, 381, 382, 383, 384, 385, 386, 387, 388, 389, 390, 391, 392, 393, 394, 395, 396, 397, 398, 399, 400, 401, 402, 403, 404, 405, 406, 407, 408, 409, 410, 411, 412, 413, 414, 415, 416, 417, 418, 419, 420, 421, 422, 423, 424, 425, 426, 427, 428, 429, 430, 431, 432, 433, 434, 435, 436, 437, 438, 439, 440, 441, 442, 443, 444, 445, 446, 447, 448, 449, 450, 451, 452, 453, 454, 455, 456, 457, 458, 459, 460, 461, 462, 463, 464, 465, 466, 467, 468, 469, 470, 471, 472, 473, 474, 475, 476, 477, 478, 479, 480, 481, 482, 483, 484, 485, 486, 487, 488, 489, 490, 491, 492, 493, 494, 495, 496, 497, 498, 499, 500, 501, 502, 503, 504, 505, 506, 507, 508, 509, 510, 511, 512, 513, 514, 515, 516, 517, 518, 519, 520, 521, 522, 523, 524, 525, 526, 527, 528, 529, 530, 531, 532, 533, 534, 535, 536, 537, 538, 539, 540, 541, 542, 543, 544, 545, 546, 547, 548, 549, 550, 551, 552, 553, 554, 555, 556, 557, 558, 559, 560, 561, 562, 563, 564, 565, 566, 567, 568, 569, 570, 571, 572, 573, 574, 575, 576, 577, 578, 579, 580, 581, 582, 583, 584, 585, 586, 587, 588, 589, 590, 591, 592, 593, 594, 595, 596, 597, 598, 599, 600, 601, 602, 603, 604, 605, 606, 607, 608, 609, 610, 611, 612, 613, 614, 615, 616, 617, 618, 619, 620, 621, 622, 623, 624, 625, 626, 627, 628, 629, 630, 631, 632, 633, 634, 635, 636, 637, 638, 639, 640, 641, 642, 643, 644, 645, 646, 647, 648, 649, 650, 651, 652, 653, 654, 655, 656, 657, 658, 659, 660, 661, 662, 663, 664, 665, 666, 667, 668, 669, 670, 671, 672, 673, 674, 675, 676, 677, 678, 679, 680, 681, 682, 683, 684, 685, 686, 687, 688, 689, 690, 691, 692, 693, 694, 695, 696, 697, 698, 699, 700, 701, 702, 703, 704, 705, 706, 707, 708, 709, 710, 711, 712, 713, 714, 715, 716, 717, 718, 719, 720, 721, 722, 723, 724, 725, 726, 727, 728, 729, 730, 731, 732, 733, 734, 735, 736, 737, 738, 739, 740, 741, 742, 743, 744, 745, 746, 747, 748, 749, 750, 751, 752, 753, 754, 755, 756, 757, 758, 759, 760, 761, 762, 763, 764, 765, 766, 767, 768, 769, 770, 771, 772, 773, 774, 775, 776, 777, 778, 779, 780, 781, 782, 783, 784, 785, 786, 787, 788, 789, 790, 791, 792, 793, 794, 795, 796, 797, 798, 799, 800, 801, 802, 803, 804, 805, 806, 807, 808, 809, 810, 811, 812, 813, 814, 815, 816, 817, 818, 819, 820, 821, 822, 823, 824, 825, 826, 827, 828, 829, 830, 831, 832, 833, 834, 835, 836, 837, 838, 839, 840, 841, 842, 843, 844, 845, 846, 847, 848, 849, 850, 851, 852, 853, 854, 855, 856, 857, 858, 859, 860, 861, 862, 863, 864, 865, 866, 867, 868, 869, 870, 871, 872, 873, 874, 875, 876, 877, 878, 879, 880, 881, 882, 883, 884, 885, 886, 887, 888, 889, 890, 891, 892, 893, 894, 895, 896, 897, 898, 899, 900, 901, 902, 903, 904, 905, 906, 907, 908, 909, 910, 911, 912, 913, 914, 915, 916, 917, 918, 919, 920, 921, 922, 923, 924, 925, 926, 927, 928, 929, 930, 931, 932, 933, 934, 935, 936, 937, 938, 939, 940, 941, 942, 943, 944, 945, 946, 947, 948, 949, 950, 951, 952, 953, 954, 955, 956, 957, 958, 959, 960, 961, 962, 963, 964, 965, 966, 967, 968, 969, 970, 971, 972, 973, 974, 975, 976, 977, 978, 979, 980, 981, 982, 983, 984, 985, 986, 987, 988, 989, 990, 991, 992, 993, 994, 995, 996, 997, 998, 999, 1000, 1001, 1002, 1003, 1004, 1005, 1006, 1007, 1008, 1009, 1010, 1011, 1012, 1013, 1014, 1015, 1016, 1017, 1018, 1019, 1020, 1021, 1022, 1023, 1024, 1025, 1026, 1027, 1028, 1029, 1030, 1031, 1032, 1033, 1034, 1035, 1036, 1037, 1038, 1039, 1040, 1041, 1042, 1043, 1044, 1045, 1046, 1047, 1048, 1049, 1050, 1051, 1052, 1053, 1054, 1055, 1056, 1057, 1058, 1059, 1060, 1061, 1062, 1063, 1064, 1065, 1066, 1067, 1068, 1069, 1070, 1071, 1072, 1073, 1074, 1075, 1076, 1077, 1078, 1079, 1080, 1081, 1082, 1083, 1084, 1085, 1086, 1087, 1088, 1089, 1090, 1091, 1092, 1093, 1094, 1095, 1096, 1097, 1098, 1099, 1100, 1101, 1102, 1103, 1104, 1105, 1106, 1107, 1108, 1109, 1110, 1111, 1112, 1113, 1114, 1115, 1116, 1117, 1118, 1119, 1120, 1121, 1122, 1123, 1124, 1125, 1126, 1127, 1128, 1129, 1130, 1131, 1132, 1133, 1134, 1135, 1136, 1137, 1138, 1139, 1140, 1141, 1142, 1143, 1144, 1145, 1146, 1147, 1148, 1149, 1150, 1151, 1152, 1153, 1154, 1155, 1156, 1157, 1158, 1159, 1160, 1161, 1162, 1163, 1164, 1165, 1166, 1167, 1168, 1169, 1170, 1171, 1172, 1173, 1174, 1175, 1176, 1177, 1178, 1179, 1180, 1181, 1182, 1183, 1184, 1185, 1186, 1187, 1188, 1189, 1190, 1191, 1192, 1193, 1194, 1195, 1196, 1197, 1198, 1199, 1200, 1201, 1202, 1203, 1204, 1205, 1206, 1207, 1208, 1209, 1210, 1211, 1212, 1213, 1214, 1215, 1216, 1217, 1218, 1219, 1220, 1221, 1222, 1223, 1224, 1225, 1226, 1227, 1228, 1229, 1230, 1231, 1232, 1233, 1234, 1235, 1236, 1237, 1238, 1239, 1240, 1241, 1242, 1243, 1244, 1245, 1246, 1247, 1248, 1249, 1250, 1251, 1252, 1253, 1254, 1255, 1256, 1257, 1258, 1259, 1260, 1261, 1262, 1263, 1264, 1265, 1266, 1267, 1268, 1269, 1270, 1271, 1272, 1273, 1274, 1275, 1276, 1277, 1278, 1279, 1280, 1281, 1282, 1283, 1284, 1285, 1286, 1287, 1288, 1289, 1290, 1291, 1292, 1293, 1294, 1295, 1296, 1297, 1298, 1299, 1300, 1301, 1302, 1303, 1304, 1305, 1306, 1307, 1308, 1309, 1310, 1311, 1312, 1313, 1314, 1315, 1316, 1317, 1318, 1319, 1320, 1321, 1322, 1323, 1324, 1325, 1326, 1327, 1328, 1329, 1330, 1331, 1332, 1333, 1334, 1335, 1336, 1337, 1338, 1339, 1340, 1341, 1342, 1343, 1344, 1345, 1346, 1347, 1348, 1349, 1350, 1351, 1352, 1353, 1354, 1355, 1356, 1357, 1358, 1359, 1360, 1361, 1362, 1363, 1364, 1365, 1366, 1367, 1368, 1369, 1370, 1371, 1372, 1373, 1374, 1375, 1376, 1377, 1378, 1379, 1380, 1381, 1382, 1383, 1384, 1385, 1386, 1387, 1388, 1389, 1390, 1391, 1392, 1393, 1394, 1395, 1396, 1397, 1398, 1399, 1400, 1401, 1402, 1403, 1404, 1405, 1406, 1407, 1408, 1409, 1410, 1411, 1412, 1413, 1414, 1415, 1416, 1417, 1418, 1419, 1420, 1421, 1422, 1423, 1424, 1425, 1426, 1427, 1428, 1429, 1430, 1431, 1432, 1433, 1434, 1435, 1436, 1437, 1438, 1439, 1440, 1441, 1442, 1443, 1444, 1445, 1446, 1447, 1448, 1449, 1450, 1451, 1452, 1453, 1454, 1455, 1456, 1457, 1458, 1459, 1460, 1461, 1462, 1463, 1464, 1465, 1466, 1467, 1468, 1469, 1470, 1471, 1472, 1473, 1474, 1475, 1476, 1477, 1478, 1479, 1480, 1481, 1482, 1483, 1484, 1485, 1486, 1487, 1488, 1489, 1490, 1491, 1492, 1493, 1494, 1495, 1496, 1497, 1498, 1499, 1500, 1501, 1502, 1503, 1504, 1505, 1506, 1507, 1508, 1509, 1510, 1511, 1512, 1513, 1514, 1515, 1516, 1517, 1518, 1519, 1520, 1521, 1522, 1523, 1524, 1525, 1526, 1527, 1528, 1529, 1530, 1531, 1532, 1533, 1534, 1535, 1536, 1537, 1538, 1539, 1540, 1541, 1542, 1543, 1544, 1545, 1546, 1547, 1548, 1549, 1550, 1551, 1552, 1553, 1554, 1555, 1556, 1557, 1558, 1559, 1560, 1561, 1562, 1563, 1564, 1565, 1566, 1567, 1568, 1569, 1570, 1571, 1572, 1573, 1574, 1575, 1576, 1577, 1578, 1579, 1580, 1581, 1582, 1583, 1584, 1585, 1586, 1587, 1588, 1589, 1590, 1591, 1592, 1593, 1594, 1595, 1596, 1597, 1598, 1599, 1600, 1601, 1602, 1603, 1604, 1605, 1606, 1607, 1608, 1609, 1610, 1611, 1612, 1613, 1614, 1615, 1616, 1617, 1618, 1619, 1620, 1621, 1622, 1623, 1624, 1625, 1626, 1627, 1628, 1629, 1630, 1631, 1632, 1633, 1634, 1635, 1636, 1637, 1638, 1639, 1640, 1641, 1		

A

B

C

D

E

TX-1000/U/TX-2000

## MECHANISM EXPLODED VIEW

1

2

3

4

5

6

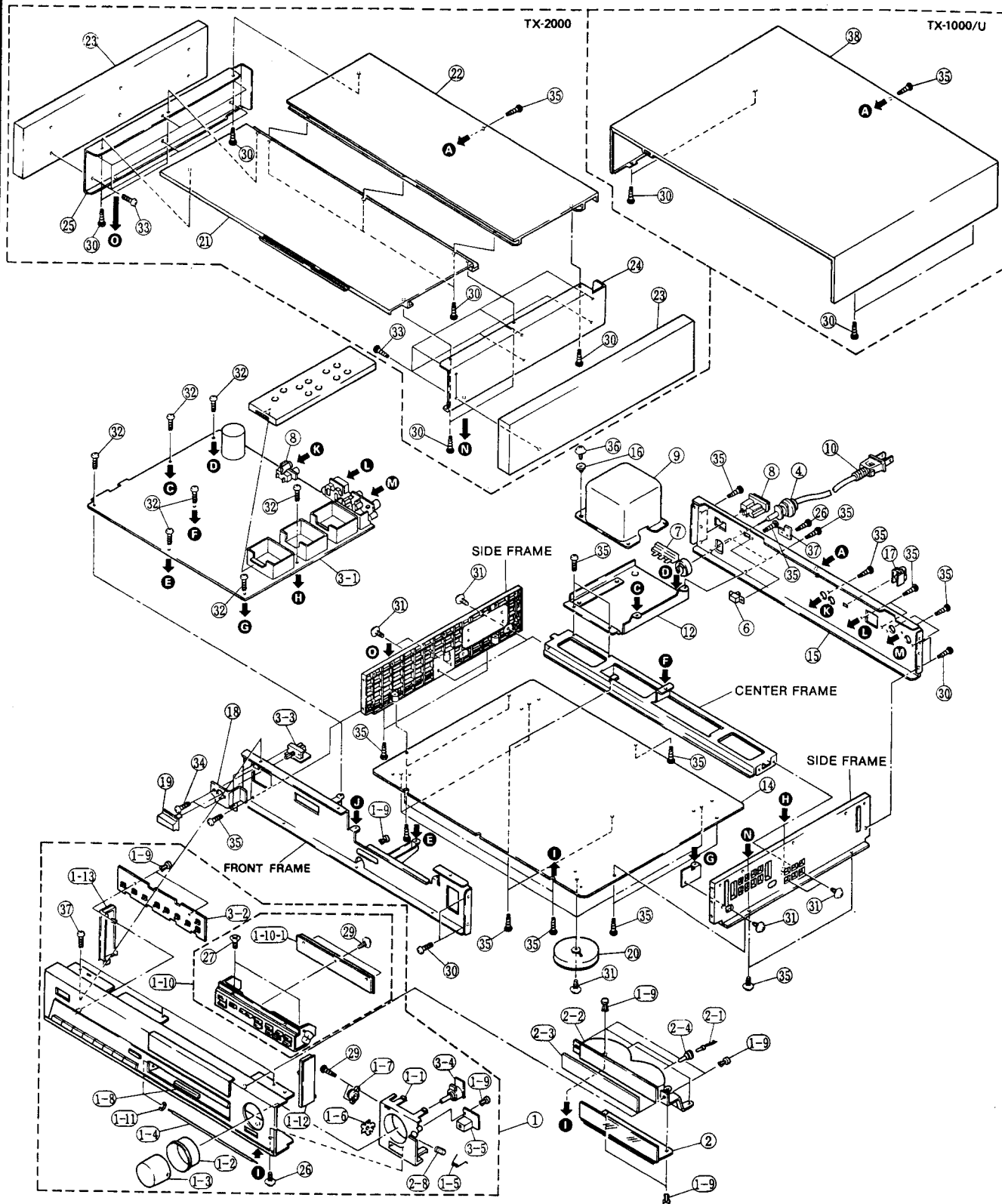

7 29

For Service Manuals Contact  
**MAURITRON TECHNICAL SERVICES**  
 8 Cherry Tree Rd, Chinnor  
 Oxon OX9 4QY  
 Tel:- 01844-351694 Fax:- 01844-352554  
 Email:- enquiries@mauritron.co.uk

Ref. No.	Part No.	Description	部 品 名	Remarks	Common Model	Markets	ランク
※	1	VF 47 07 00	Panel Unit		パネルユニット	TX-1000U	U, C
※	※	VF 47 08 00	※		※	TX-1000	R, A, B, G
※	※	VF 46 86 00	※		※	TX-2000	
※	1-1	VF 44 54 00	Plate Tuning		プレートチューニング		
※	1-2	VF 20 87 00	Escutcheon	TUNE	エスカッション	TX-1000/U	
※	※	VF 20 85 00	※	※	※	TX-2000	
※	1-3	VF 20 89 00	Knob Tuning		ノブチューニング	TX-1000/U	
※	※	VF 20 88 00	※		※	TX-2000	
※	1-4	VF 21 09 00	Shaft		シャフト		
※	1-5	VF 20 75 00	Spring K		スプリング K		
※	1-6	VF 20 67 00	Washer Friction		ワッシャーフリクション		
※	1-7	PB 06 49 40	Damper	IC72-E	ダンパー		
※	1-8	VF 20 96 00	Cushion		クッション		
※	1-9	CB 60 56 20	Plastic Rivet		プラスチックリベット		
※	1-10	VG 46 41 00	Sub Panel B Ass'y		サブパネル B Ass'y	TX-1000/U	
※	※	VG 46 40 00	※		※	TX-2000	
※	1-10-1	VF 43 17 00	Function Sheet		ファンクションシート		
※	1-11	EV 50 12 56	E Ring	2.5 FNM3-3G	E リング	PACK	
※	1-12	VF 20 70 00	Side Cover L		サイドカバー L	TX-1000	
※	1-13	VF 20 74 00	※ R		※ R	※	
※	2	NA 09 91 00	LCD Circuit Board		LCD 表示シート	TX-1000/U	
※	※	NA 09 90 90	※		※	TX-2000	
※	2-1	VF 46 60 00	Lamp	8V 150mA	ランプ		
※	2-2	VF 20 68 00	Reflector		リフレクタ		
※	2-3	VF 21 10 00	Sheet Diffusion		シートディフュージョン		
※	2-4	VF 44 45 00	Lamp Cap		ランプキャップ		
※	3	NA 09 90 40	Tuner Circuit Board		チューナーシート		J
※	※	NA 09 90 50	※		※		U, C
※	※	NA 09 90 60	※		※		R
※	※	NA 09 90 70	※		※	TX-1000/U	A, B
※	※	NA 09 90 80	※		※		W/G
※	4	CB 62 01 90	Cord Stopper	CM-22B	コードストッパー		R, A, B, W/G
※	※	CB 62 02 00	※	CM-22C	※		U, C
※	5	HG 30 92 20	Carbon Resistor	2.2MΩ 1/2W	カーボン抵抗		U, C
※	6	KA 40 16 80	Slide Switch		スライドスイッチ	Voltage Selector	R
※	7	LA 00 10 00	Lag Terminal		ラグ端子板		U, C
※	※	VD 61 41 00	Terminal	2P	中継端子板		A, B, W/G
※	8	LB 20 30 60	AC Outlet		AC アウトレット	TX-2000	J
※	9	XE 24 70 01	Power Transformer		電源トランス		J
※	※	XE 24 80 01	※		※		U, C
※	※	XE 24 90 01	※		※		R
※	※	XE 67 90 01	※		※		W
※	※	XE 67 90 01	※		※	TX-1000/U	A, B, G
※	10	VC 61 44 00	Power Cord	12A 125V	電源コード	TX-2000	AX-900
※	※	MG 00 22 20	※	10A 125V	※		U, C
※	※	MG 00 16 30	※	6A 250V	※		R
※	※	MG 00 23 10	※	7.5A 250V	※	TX-1000/U	A
※	※	MG 00 23 30	※	300/300V	※		B
※	※	MG 00 23 20	※	2.5A 250V	※		W/G
※	11	VF 44 56 00	Shield Case C		シールドケース C		
※	12	AA 62 17 80	Holder, Transformer		トランスホルダー	TX-1000/U	C-80
※	※	VF 44 65 00	※		※	TX-2000	

※New Parts (新規部品)

For Service Manuals Contact  
**MAURITRON TECHNICAL SERVICES**  
 8 Cherry Tree Rd, Chinnor  
 Oxon OX9 4QY  
 Tel: 01844-351694 Fax: 01844-352554  
 Email: enquiries@mauritron.com

Ref. No.	Part No.	Description	部 品 名	Remarks	Common Model	Markets	ランク
13	CA 07 59 40	Spacer, Transformer	トランススパーサー				
※	14	VF 67 79 00	Bottom Cover	ボトムカバー	TX-1000/U	C-60	
※	◇	VF 44 55 00	◇	◇	TX-2000		
※	15	VF 20 92 00	Rear Panel	リアパネル	TX-1000/U		U, C
※	◇	VF 20 93 00	◇	◇	◇		R
※	◇	VF 20 94 00	◇	◇	◇		G
※	◇	VF 20 95 00	◇	◇	◇		A, B
※	◇	VF 20 91 00	◇	◇	TX-2000		J
※	◇	VF 44 57 00	◇	◇	◇		U, C
※	◇	VF 44 58 00	◇	◇	◇		R
◇	VF 44 59 00	◇	◇	◇	◇		W
16	CB 62 30 40	Bushing	絶縁ブッシュ		A-750		
17	CB 60 74 70	Holder, Antenna	アンテナホルダー			R, G	
※	18	VF 34 04 00	Support P	サポートP			
※	19	VE 70 75 00	Button	ボタン	POWER TX-1000/U		
※	◇	VF 44 61 00	◇	◇	◇ TX-2000		
20	NB 62 01 40	Leg Ass'y	レッグ Ass'y		TX-1000/U		
◇	VE 13 39 00	◇	GY	◇		DSP-3000	
※	21	VF 44 48 00	Top Cover	Front	トップカバー	TX-2000	
※	22	VF 44 49 00	◇	Rear	◇	◇	
※	23	VF 44 50 00	Side Cover	WL/WR	サイドカバー	◇	
※	24	VF 44 52 00	Support Wood L		サポートウッドL	◇	
※	25	VF 44 53 00	Support Wood R		サポートウッドR	◇	
26	EX 60 08 40	B.W.Head Tapping Screw	2 x 6 FCM3-BL	BWヘッドタッピングネジ			
27	EO 32 00 66	Flat Head Tapping Screw	2 x 6 FCRM3-3I	皿タッピングネジ	PACK TX-1000/U		
◇	EO 12 00 66	◇	◇ FCRM3-3G	◇	◇ TX-2000		
28	EK 03 60 60	B.W.Head Tapping Screw	2 x 4 ZMC2-Y	BWヘッドタッピングネジ			
29	Ei 32 00 66	Bind Head Tapping Screw	2 x 6 ZMC2-Y	バインドタッピングネジ	PACK		
30	Ei 33 00 86	◇	3 x 8 FCM3-BL	◇	◇		
31	EK 33 60 10	B.W.Head Tapping Screw	3 x 8 FCM3-BL	BWヘッドタッピングネジ			
32	EK 03 00 60	◇	3 x 8 YMC2-Y	◇			
33	EQ 03 11 06	Round Head Wood Screw	3.1 x 10 ZMC2-Y	マルモクネジ	TX-2000		
34	ED 33 00 66	Bind Head Screw	3 x 6 FCM3-BL	バインド小ネジ	PACK		
35	EZ 00 04 60	Bind Head Bonding Screw	3 x 8 FCM3-BL	ボンディングBタイトネジ			
36	EX 60 08 50	Cup Screw	4 x 10 FCM3-BL	カップBタイトネジ			
37	CB 60 14 40	VS Stopper		VSストッパー			R
38	VF 20 65 00	Top Cover		トップカバー	TX-1000/U		
	CB 06 92 50	Binding Tie	BK-1	バインドタイ			
		<b>Accessories</b>		<b>付 属 品</b>			
※	VF 43 20 00	Remote Control Transmitter	RS-TX2000	リモコンユニット	TX-2000		
※	VF 43 18 00	◇	RS-TX1000	◇	TX-1000/U		
	VE 36 62 00	Loop Antenna	AM	ループアンテナ	TX-2000		
	VE 36 62 00	◇	◇	◇	TX-1000		U,C,A,B
	VD 63 29 00	◇	◇	◇	◇		R
	Mi 08 28 40	FM Q match Antenna		FM Qマッチアンテナ			J
	VG 08 73 00	◇		◇			U,C,R,A,B,W/G
※	VF 66 47 00	Pin-Plug Cord		ピンプラグコード	TX-2000		
	Mi 08 87 90	◇		◇	TX-1000/U		
※	VE 19 22 00	Antenna Plug	75---300 NTSC	プラグアンテナ			J,U,C,R
	VE 36 49 00	◇	75---300 PAL	◇			W/G
		Dry Cell	AA, R6	単 3 乾 電 池			

※New Parts (新規部品)

For Service Manuals Contact  
**MAURITRON TECHNICAL SERVICES**  
 8 Cherry Tree Rd, Chinnor  
 Oxon OX9 4QY  
 Tel:- 01844-351694 Fax:- 01844-352554  
 Email:- enquiries@mauritron.co.uk

## Part List for Carbon Resistor

Value	1/4W Type Part No.	1/6W Type Part No.	Value	1/4W Type Part No.	1/6W Type Part No.
1.0Ω	HJ35 3100	※	12KΩ	HJ35 7120	HF85 7120
1.8 "	HJ35 3180	※	15 "	HJ35 7150	HF85 7150
2.2 "	HJ35 3220	HF85 3220	18 "	HJ35 7180	HF85 7180
3.3 "	HJ35 3330	HF85 3330	22 "	HJ35 7220	HF85 7220
4.7 "	HJ35 3470	HF85 3470	27 "	HJ35 7270	HF85 7270
5.6 "	HJ35 3560	HF85 3560	33 "	HJ35 7330	HF85 7330
10 "	HJ35 4100	HF85 4100	39 "	HJ35 7390	HF85 7390
15 "	HJ35 4150	HF85 4150	47 "	HJ35 7470	HF85 7470
22 "	HJ35 4220	HF85 4220	56 "	HJ35 7560	HF85 7560
27 "	HJ35 4270	HF85 4270	68 "	HJ35 7680	HF85 7680
33 "	HJ35 4330	HF85 4330	82 "	HJ35 7820	HF85 7820
39 "	HJ35 4390	HF85 4390	91 "	HJ35 7910	HF85 7910
47 "	HJ35 4470	HF85 4470	100 "	HJ35 8100	HF85 8100
56 "	HJ35 4560	HF85 4560	120 "	HJ35 8120	HF85 8120
68 "	HJ35 4680	HF85 4680	150 "	HJ35 8150	HF85 8150
82 "	HJ35 4820	HF85 4820	180 "	HJ35 8180	HF85 8180
100 "	HJ35 5100	HF85 5100	220 "	HJ35 8220	HF85 8220
110 "	HJ35 5110	HF85 5100	270 "	HJ35 8270	HF85 8270
120 "	HJ35 5120	HF85 5120	330 "	HJ35 8330	HF85 8330
150 "	HJ35 5150	HF85 5150	390 "	HJ35 8390	HF85 8390
160 "	HJ35 5160	※	470 "	HJ35 8470	HF85 8470
180 "	HJ35 5180	HF85 5180	560 "	HJ35 8560	HF85 8560
220 "	HJ35 5220	HF85 5220	680 "	HJ35 8680	HF85 8680
270 "	HJ35 5270	HF85 5270	820 "	HJ35 8820	HF85 8820
330 "	HJ35 5330	HF85 5330	1.0MΩ	HJ35 9100	HF85 9100
390 "	HJ35 5390	HF85 5390	1.2 "	HJ35 9120	※
470 "	HJ35 5470	HF85 5470	1.5 "	HJ35 9150	HF85 9150
510 "	※	HF85 5510	1.8 "	HJ35 9180	HF85 9180
560 "	HJ35 5560	HF85 5560	2.2 "	HJ35 9220	HF85 9220
680 "	HJ35 5680	HF85 5680	3.3 "	HJ35 9330	HF85 9330
820 "	HJ35 5820	HF85 5820	3.9 "	HJ35 9390	※
910 "	HJ35 5910	HF85 5910	4.7 "	HJ35 9470	※
1.0KΩ	HJ35 6100	HF85 6100			
1.2 "	HJ35 6120	HF85 6120			
1.5 "	HJ35 6150	HF85 6150			
1.8 "	HJ35 6180	HF85 6180			
2.0 "	HJ35 6200	HF85 6200			
2.2 "	HJ35 6220	HF85 6220			
2.4 "	HJ35 6240	HF85 6240			
2.7 "	HJ35 6270	HF85 6270			
3.0 "	HJ35 6300	HF85 6300			
3.3 "	HJ35 6330	HF85 6330			
3.6 "	HJ35 6360	HF85 6360			
3.9 "	HJ35 6390	HF85 6390			
4.7 "	HJ35 6470	HF85 6470			
5.1 "	HJ35 6510	HF85 6510			
5.6 "	HJ35 6560	HF85 6560			
6.8 "	HJ35 6680	HF85 6680			
8.2 "	HJ35 6820	HF85 6820			
9.1 "	HJ35 6910	HF85 6910			
10 "	HJ35 7100	HF85 7100			

1/4W Type

HJ35 ○○○○

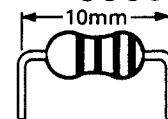

1/6W Type

HF85 ○○○○

